

**SEED-DRILLS:
JET-X**



JET-X

Code : Q00A00163

**Use and
maintenance manual**

**Translation of original
instructions**



Read these instructions carefully before using the first time.



Strictly confidential information - All rights to the contents of this document are reserved. It is forbidden to copy, use, distribute, even partially or otherwise disclose such information, unless expressly authorised by "ALPEGO S.p.a.". Violations will be prosecuted in accordance with the law.

Table of contents

SOMMARIO	3
LISTA FIGURE	4
LISTA TABELLE	5
1 GENERAL INFORMATIONI	10
1.1 Purpose of the manual.....	10
1.2 Documents supplied with the machine	10
1.3 Warranty	11
1.4 Updating the manual.....	11
1.4.1 Symbols used in this manual	12
1.5 Manufacturer's name and address	12
1.6 Machine identification	13
2 TECHNICAL SPECIFICATIONS	14
2.1 Machine description.....	14
2.2 JET-X seed-drill components.....	15
2.3 Technical specifications of the machine.....	16
2.3.1 JET-X technical specifications	16
2.4 Sound level.....	16
3 SAFETY REGULATIONS.....	17
3.1 Use in machine safety	17
3.2 Hydraulic connections.....	18
3.3 Carrying out maintenance safely	18
3.4 Circulating on roads	19
3.5 Clothing	19
3.6 Ecology.....	20
3.7 Safety signals	20
4 INSTALLATION	22
4.1 Lifting the machine.....	22
4.2 Applying the seed box fast coupling	23
4.3 Connection of the front hopper with ALPEGO machine.....	23
4.4 Connecting of seeding bar.....	25
4.4.1 Installing quick hooks	25
4.4.2 Assembly of the following harrow	26
4.4.3 Assembly of the distribution head.....	27
4.4.4 Hitching the seeding bar	27
4.4.5 Connecting the seed-conveying hose.....	29
4.5 Assembly of the rear lights	30
4.6 Electric wiring of the seeder bar	30
4.7 3-point switch.....	31

5	USER INSTRUCTIONS	35
5.1	Oleodynamic blower movement	35
5.1.1	Hydraulic connection with the tractor.....	35
5.1.2	Starting	36
5.1.3	Oil cooling.....	37
5.2	Distribution.....	37
5.3	Adjustment of the following harrow.....	38
5.4	Regulating the sowing depth	38
5.5	Adjustment of the coulter-disc scraper	39
5.6	Unhitching the seed-drill	39
5.6.1	Unhitching the seeder bar.....	39
5.6.2	Unhitching the hopper.....	41
6	MAINTENANCE	42
6.1	Checks and controls	42
6.2	Lubrication	42
6.3	Emptying the seed from the hopper.....	43
6.4	End of season operations	43
7	ACCESSORIES	44
7.1	Row marking	44
7.2	Pre-sprouting discs.....	44
7.3	Hydraulic seeding exclusion	45
7.4	Press wheel	46
7.5	Hopper extension	47

List of figures



The images in this manual are for illustrative purposes only and may not always accurately represent the appearance of the product or its application.

Fig. 1	Running direction.....	9
Fig. 2	Marking data.....	13
Fig. 3	JET-X Seed-Drill Components.....	15
Fig. 4	Angle cardan shaft.....	18
Fig. 5	Protection systems	19
Fig. 6	Lifting the machine.....	22
Fig. 7	Applying the seed box fast coupling	23
Fig. 8	Connection of the front hopper with ALPEGO machines.....	24
Fig. 9	Connection of the front hopper with ALPEGO machines.....	24
Fig. 10	Connection of the front hopper with ALPEGO machines.....	24
Fig. 11	Installing quick hooks	25
Fig. 12	Assembly of the following harrow	26
Fig. 13	Assembly of the distribution head.....	27
Fig. 14	Hitching the seeding bar	27
Fig. 15	Hitching the seeding bar	28

Fig. 16 Hitching the seeding bar	28
Fig. 17 Connecting the seed-conveying hose.....	29
Fig. 18 Assembly of the rear lights	30
Fig. 19 Electric wiring of the seeder bar	30
Fig. 20 3-point switch.....	31
Fig. 21 Microswitch rod	32
Fig. 22 Microswitch bracket	32
Fig. 23 Work position	32
Fig. 24 Lifted position.....	32
Fig. 25 Checking the raising capacity and tractor stability.....	33
Fig. 26 Hydraulic connection with the tractor.....	36
Fig. 27 Distribution.....	37
Fig. 28 Adjustement of the following harrow.....	38
Fig. 29 Regulating the sowing depth	38
Fig. 30 Adjustment of the coulter-disc scraper	39
Fig. 31 Unhitching the seeder bar.....	40
Fig. 32 Unhitching the seeder bar.....	40
Fig. 33 Unhitching the seeder bar.....	40
Fig. 34 Unhitching the hopper.....	41
Fig. 35 Unhitching the hopper.....	41
Fig. 36 Unhitching the hopper.....	41
Fig. 37 Emptying the seed from the hopper.....	43
Fig. 38 Row marking.....	44
Fig. 39 Pre-sprouting discs	44
Fig. 40 Hydraulic seeding exclusion	45
Fig. 41 Press wheel	46
Fig. 42 Press wheel	46
Fig. 43 Hopper extension	47

List of tables

Tab. 1 Documents supplied with the machine	10
Tab. 2 JET-X Seed-Drill Components.....	15
Tab. 3 JET-X Technical specifications	16
Tab. 4 Safety signs applied to the machine	20
Tab. 5 Checks and controls (Nm)	42

<p>ITALIANO</p> <p>Dichiarazione di conformità CE Seminatrice combinata solo su attrezzatura Alpego</p> <p>Al sensi della Direttiva Europea 2006/42 CE - 2014/30 UE la ditta dichiara sotto la propria responsabilità che la macchina agricola sotto indicata è conforme ai requisiti essenziali di sicurezza e di tutela della salute previsti dalla Direttiva Europea. Per l'adeguamento della macchina sono state adottate le norme: EN ISO 4254-1:2015 - EN ISO 4254-9:2018 EN15811:2014 La persona autorizzata a compilare il fascicolo tecnico è il Direttore Tecnico di Alpego presso la sede aziendale.</p>	<p>FRANCAIS</p> <p>Déclaration de conformité CE Semoir combiné uniquement sur équipement Alpego</p> <p>conforme à la Directive Européenne de la 2006/42 CE - 2014/30 UE Nous déclarons sous notre seule responsabilité que la machine agricole faisant l'objet de la déclaration est conforme aux prescriptions fondamentales en matière de sécurité et de santé stipuées dans la Directive Européenne. Pour l'adaptation d'elle on éponge ont été adoptés les normes : EN ISO 4254-1:2015 - EN ISO 4254-9:2018 EN15811:2014 La personne autorisée à constituer le dossier technique est le Directeur Technique d'Alpego au siège de la société.</p>
<p>ENGLISH</p> <p>EC Certificate of conformity Combined seed drill only on Alpego-geräten</p> <p>conforming to European Directive 2006/42 EC - 2014/30 UE We declare in sole responsibility, that the agricultural machine to which this applies, conforms to the basic safety and health requirements of European Directive. For the adaptation of it blots some have been adopted the norms: EN ISO 4254-1:2015 - EN ISO 4254-9:2018 EN15811:2014 The person authorized to draw up the technical dossier is the Technical Director of Alpego at the company headquarters.</p>	<p>DEUTSCH</p> <p>EG Konformitätserklärung Säkombination nur auf Alpego-geräten</p> <p>entsprechend der Europäischen Richtlinie 2006/42 EG - 2014/30 UE Wir erklären in alleiniger Verantwortung, da das Landmaschine auf das sich diese Erklärung bezieht, den einschlägigen grundlegenden Sicherheits und Gesundheitsanforderungen der Europäischen Richtlinie. Für die Anpassung von ihr befolgt einige sind angenommen worden die Normen: EN ISO 4254-1:2015 - EN ISO 4254-9:2018 EN15811:2014 Die zur Erstellung der Technischen Dokumentation befugte person ist der technische Direktor von Alpego am Firmensitz.</p>
<p>ESPAÑOL</p> <p>Declaración de conformidad CE Sembradora combinada solo con equipo Alpego</p> <p>Conforme a la Directiva Europea 2006/42 CE - 2014/30 UE la empresa declara bajo su propia responsabilidad que la maquinaria agrícola modelo, está conforme a los requisitos esenciales de seguridad y de defensa de la Directiva Europea. Para la equipación de las máquinas han sido adoptadas las normas EN ISO 4254-1:2015 - EN ISO 4254-9:2018 EN15811:2014 La persona autorizada para preparar el expediente técnico es el Director Técnico de Alpego en la sede de la empresa.</p>	<p>Ελληνικά</p> <p>Δήλωση συμμόρφωσης ΕΚ Σπαστική συνδυασμένη μόνο με εξοπλισμό Alpego</p> <p>Σύμφωνα με την Ευρωπαϊκή Οδηγία 2006/42 ΕΚ - 2014/30 UE, η εταιρεία δηλώνει υπεύθυνα ότι το γεωργικό μηχάνημα που αναφέρεται παρακάτω συμμορφώνεται με τις βασικές απαιτήσεις υγείας και ασφάλειας της Ευρωπαϊκής Οδηγίας. Για την προσαρμογή του μηχανήματος έχουν υιοθετηθεί τα εξής πρότυπα: EN ISO 4254-1:2015 - EN ISO 4254-9:2018 EN15811:2014 Το πρότυπο που έχει εξουσιοδοτηθεί για την κατάρτιση του τεχνικού φακέλου είναι ο Τεχνικός Διευθυντής της Alpego, στην έδρα της εταιρείας.</p>
<p>PORTUGUES</p> <p>Declaração de conformidade CE Semeadora combinada somente com equipamento Alpego</p> <p>Nos termos da Diretiva Europeia 2006/42 CE - 2014/30 UE, a empresa declara sob a própria responsabilidade que a máquina agrícola indicada abaixo está em conformidade com os requisitos essenciais de segurança e de tutela da saúde previstos pela Diretiva Europeia. Para a adequação da máquina, foram adotadas as seguintes normas: EN ISO 4254-1:2015 - EN ISO 4254-9:2018 EN15811:2014 A pessoa autorizada para a realização do arquivo técnico é o Diretor Técnico de Alpego junto à sede da empresa.</p>	<p>NEDERLANDS</p> <p>EG-Conformiteitsverklaring Gecombineerde zaaimachine alleen op Alpego uitrusting</p> <p>In de zin van Europese Richtlijn 2006/42 EG - 2014/30 UE verklaart het bedrijf op eigen verantwoordelijkheid dat de hieronder vermelde landbouwmachine in overeenstemming is met de essentiële veiligheids- en gezondheidsdoelen die door de Europese Richtlijn beoogd worden. Voor de aanpassing van de machine zijn de volgende normen gebruikt: EN ISO 4254-1:2015 - EN ISO 4254-9:2018 EN15811:2014 De persoon die bevoegd is om het technische dossier samen te stellen is de Technisch Directeur van Alpego bij de vestiging van de onderneming.</p>
<p>MAGYAR</p> <p>EK megfeleléségi nyilatkozat Kombinált vetőgép csak Alpego felszereléséken</p> <p>Az Európai Unió 2006/42/EK - 2014/30 UE irányelve értelmében a vállalat saját felelőssége alatt kijelenti, hogy az alábbi mezőgazdasági gép megfelel az Európai Irányelv által előírt lényeges biztonsági és egészségvédelmi követelményeknek. A gép megfeleltetéséhez az alábbi szabványok kerültek alkalmazásra: EN ISO 4254-1:2015 - EN ISO 4254-9:2018 EN15811:2014 A műszaki dokumentáció összeállítására jogosult személy a vállalati székhelyen az Alpego Műszaki Igazgatója.</p>	<p>ROMÂNĂ</p> <p>Declarație de conformitate CE Semănătoare combinată numai pe echipamente Alpego</p> <p>În conformitate cu Directiva Europeană 2006/42 CE - 2014/30 UE societatea declară pe proprie răspundere că mașina agricolă indicată mai jos este conformă cerințelor esențiale în materie de siguranță și de protecție a sănătății prevăzute de Directiva Europeană. Pentru adaptarea mașinii au fost adoptate următoarele standarde: EN ISO 4254-1:2015 - EN ISO 4254-9:2018 EN15811:2014 Persoana autorizată să întocmească documentația tehnică este Directorul Tehnic al Alpego de la sediul societății.</p>
<p>POLSKI</p> <p>Deklaracja zgodności WE Siewnik kombinowany tylko na sprzęcie Alpego</p> <p>Zgodnie z treścią dyrektywy Unii Europejskiej 2006/42 WE - 2014/30 UE, firma oświadcza na własną odpowiedzialność, że wymieniona poniżej maszyna rolnicza jest zgodna z podstawowymi wymaganiami dotyczącymi bezpieczeństwa i ochrony zdrowia określonymi w Dyrektywie Europejskiej. W celu dostosowania maszyny zastosowano następujące normy: EN ISO 4254-1:2015 - EN ISO 4254-9:2018 EN15811:2014 Osobą upoważnioną do opracowania dokumentacji technicznej jest Dyrektor Techniczny Alpego w siedzibie firmy.</p>	<p>SUOMI</p> <p>EU-vaatimusten mukaisuusvakuutus Yhdistelmäkylvökone vain Alpego-laitteisiin</p> <p>EU-direktiivin 2006/42 EY - 2014/30 UE mukaisesti yritys vakuuttaa omalla vastuullaan, että alla mainittu maatalouskone täyttää EU-direktiivin mukaiset olennaiset turvallisuus- ja terveysvaatimukset. Koneen mukauttamista varten on otettu käyttöön seuraavat standardit: EN ISO 4254-1:2015 - EN ISO 4254-9:2018 EN15811:2014 Teknisen tiedotteen kokonaiseen valmistettu henkilö on Alpegon tekninen johtaja yrityksen pääkonttorissa.</p>

Codice / Code : ArticoloHY

Lonigo: gg/mm/aa

Serial:Matricola

ALPEGO S.p.a. con Socio Unico

PEGORARO LUCA

Luca Pegoraro



ALPEGO S.p.a. con Socio Unico
Società soggetta a direzione e coordinamento di Torrico S.p.A.
Via Giovanni e Giuseppe Cenzato, 9
36045 Lonigo (VI) - Italy

Tel +39 0444 64.61.00
e-mail: info@alpego.com
website: www.alpego.com

Capitale Sociale € 2.000.000 i.v.
Cod. Fisc. / Part. IVA EORI IT02009840246
REX ITREXIT02009840246
R.E.A. 199795/VI/1996
Reg. Imp. VI N° 22374/VI/1996
N. Mecc. VI 011754

UK Declaration of Conformity

We as the manufacturers:

ALPEGO S.p.a con Socio Unico

VIA Giovanni e Giuseppe Cenzato, 9
36045 Lonigo (VI) ITALIA

conforming to:

The Supply of Machinery (Safety) Regulations 2008 - S.I. 2008/1597

declare under our sole responsibility, that the agricultural machine (combined seed drill only on Alpego equipment):

Codice / Code : **ArticoloHY**

Serial:Matricola

fulfils all the relevant provisions of **The Supply of Machinery (Safety) Regulations 2008**, and also fulfils all the relevant provisions of the following UK Regulations:

- Electromagnetic Compatibility Regulations 2016.

The machine referenced above is manufactured in accordance with the following designated standards:

EN ISO 4254-1:2015
EN ISO 4254-9:2018
EN 15811:2014

The person authorized to draw up the technical file is the Technical Director of Alpego at the company headquarters

Lonigo: **gg/mm/aaaa**

ALPEGO S.p.a. con Socio Unico

PEGORARO LUCA
Chief Technology Officer





Strictly confidential information - All rights to the contents of this document are reserved. It is forbidden to copy, use, distribute, even partially or otherwise disclose such information, unless expressly authorised by "ALPEGO S.p.a.". Violations will be prosecuted in accordance with the law.

Read this manual thoroughly before using the machine. Being well informed is essential for safe machine usage. This manual should be kept for the whole working life of the machine.

Thank you for choosing us. You have purchased an excellent quality product that is guaranteed by decades of experience.

On leaving the factory, each machine is accurately inspected to guarantee the absence of defects.

Should any material defect be found in spite of inspection, please contact your dealer immediately.

Please contact us if you need further information or if something needs to be clarified.

Our aim is to constantly improve the product and keep it top level.



AS THE TRIANGLE INDICATES DANGER, PLEASE BE CAREFUL WHEN IT APPEARS!

THE TERM MACHINE IS USED TO INDICATE THE COMMERCIAL NAME OF THE PRODUCT TO WHICH THIS MACHINE REFERS



ALL INFORMATION CONTAINED IN THIS MANUAL IS INFORMATIVE AND DOES NOT BIND THE PRODUCER. THE INFORMATION CONTAINED HEREIN CAN BE CHANGED WITHOUT FOREWARNING.

N.B.: view of the machine. **ALPEGO** normally considers the machine as being viewed from the rear to identify better the particulars and to better assemble the parts that must respect the position "right or left" as in description (e.g.: right or left cardan joint, right or left tine, etc.)

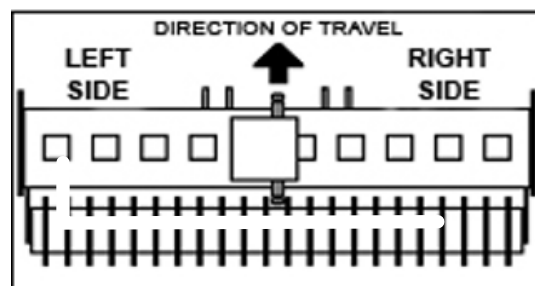

Fig. 1 Running direction

1 GENERAL INFORMATION

1.1 Purpose of the manual

This manual was created by the machine producer and is an integral part of the documentation that accompanies the machine.

The use of the combined machine (power harrow / rotary tiller / cultivator with seeder) defines this manual as an integral part of the use and maintenance manual of the power harrow or the rotary tiller or the cultivator.

The manual defines the purpose for which the machine was produced, it establishes correct machine application and limits of use.

The constant application of the indications given in this manual guarantees the safety of those who use the machine, as well as working economy and longer machine duration.

This manual has been divided into sections. To make it easier to find a specific topic, consult the initial index.

The images that appear in this manual are given as an example. Even if substantially different from the machine you possess, the safety and information are guaranteed.

The Manufacturer reserves the right to modify the implement without promptly updating this issue. In case of dispute the valid reference text remains the Italian version.

1.2 Documents supplied with the machine

The following documents should be supplied with the machine::

- User and maintenance manual
- Spare parts catalogue
- EC Conformity Declaration

The machine may be supplied complete with different options/fittings. For the assembly and the use of those check the specific manuals supplied with the documents of the machine.

Cod.	Description
D16555	Owner's Manual of the DOSAL metering unit
Q15A00119	Owner's Manual of the row-marking discs
Q15A00159	Owner's Manual of the "ISOBUS" Computer

Tab. 1 Documents supplied with the machine

1.3 Warranty

When delivered, make sure that the machine and any accessories were not damaged during transport. Any complaints should be presented in writing within 6 days from the date of delivery.

WARRANTY FORFEITURE

The guarantee is rendered null and void immediately if:

- there is a manoeuvring error
- the instructions described in this manual are not followed
- original spare parts are not used
- any modification is made to the machine without having obtained authorisation from the manufacturer.
- bolt or material other than those specified are used
- If the maximum power limit allowed is exceeded

The warranty only covers design, assembly and painting defects and exclusively in the case of use of the product in accordance with the instructions provided in this instruction manual;
The Seller is not liable for components supplied by third parties and installed on its machines.
For what is not expressly foreseen therein, please refer to the general sales conditions.

1.4 Updating the manual

The information, descriptions and illustrations contained in this manual reflect the state of the art at the time the machine, of which it is an integral part, was placed on the market and complies with all laws, directives and standards applicable at that time; it cannot be considered inadequate simply because it has been subsequently updated on the basis of new experience.

Any modifications, adjustments, etc. made to machines subsequently marketed do not oblige the manufacturer to intervene on the machine previously supplied or to consider it and its manual as deficient or inadequate.

Any additions to the manual that the manufacturer deems appropriate to send to users must be kept together with the manual and form an integral part thereof.



The manufacturer reserves the material and intellectual property rights of this publication and prohibits its dissemination and duplication, even in part, without his prior written consent.

1.4.1 Symbols used in this manual

Below are the various symbols used in the manual to highlight particularly important information:



WARNING - To indicate special information.



CAUTION DANGER - To indicate actions which, if not carried out correctly, may cause general accidents or may generate malfunctions or material damage to the machine; they therefore require particular attention and suitable training.



IT IS FORBIDDEN - To indicate actions that **MUST NOT** be performed.



To indicate the personal protective equipment that personnel must wear to carry out a specific operation.

1.5 Manufacturer's name and address

The manufacturer's identification data are given below:

ALPEGO S.p.A.

Administrative headquarters and Registered office : Via Giovanni e Giuseppe Cenzato, 9
36045 LONIGO (VICENZA) - ITALY

Tel: +39 0444/646100

Fax: +39 0444/646199

E-mail: info@alpego.com

Website: www.alpego.com

1.6 Machine identification

The machine covered by this manual is identified by the serial number label with its technical characteristics, located at the point indicated at Fig. 2.

The label must NEVER BE REMOVED until the machine is decommissioned, at which time it is removed from the support and destroyed.

The serial number unambiguously identifies the machine, makes it possible to trace its specific characteristics and identify the components installed in it. Without this number it is not possible to identify product-specific spare parts with certainty.

Always provide the type of machine and the serial number, or at least the serial number, in the event of a call-out. The registration plate is characterised by the following entries:

1. Machine model.
2. Machine serial number.
3. Maximum weight.
4. Date of manufacture.

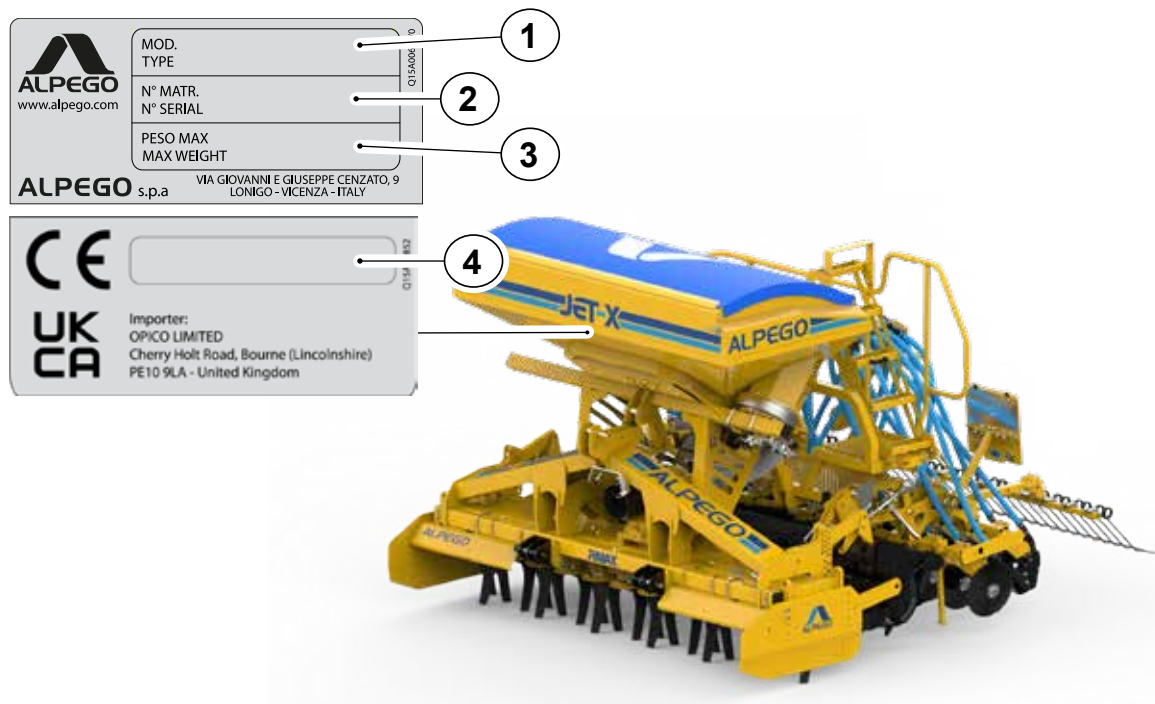

Fig. 2 Marking data



IT IS FORBIDDEN to remove, cover, move or damage the machine's identification plate.

In case the nameplate should deteriorate or become poorly visible or missing, it is mandatory to replace it by requesting it directly from ALPEGO S.p.a.

2 TECHNICAL SPECIFICATIONS

2.1 Machine description

The mod. JET-X seed-drill should only be used for working agricultural ground. If used in manners other than those described in this manual, the machine can be damaged and become dangerous for the user. The seeder mod. JET-X is suitable for use combined with implements Alpego for the preparation of the soil.

The mod. JET-X seed-drill can be used with equipment for working the ground in combination with a suitable assembly kit.

The mod. JET-X seed-drill is suitable for sowing cereal: wheat, barley, rye, oats, rice; fine seeds and fodder: rape, clover, alfalfa; large seeds: soy, peas.

The seeds are deposited in the soil by means of disc coulters and they are distributed continuously; the distributed quantities are regulated by an electric motor. The seeds are distributed and transported to the coulters by compressed air. The air is produced by a fan that is moved hydraulically.

The disc is mounted on a super-elastic support that gives excellent depth and pressure on the ground, regulating the height of the seed bar.

For the plan and the realization of the machine in object they have been examined and continuations the Norms of the directive 2006/42 CE which:

- UNI EN 14018
- UNI EN ISO 4254-1
- UNI EN ISO 13857
- UNI EN ISO 4254-5
- ISO 11684
- UNI EN ISO 4413

The machine will operate well if used correctly and if the correct maintenance is carried out. It is therefore advisable to follow what is indicated in this manual in order to prevent any inconvenience that could prejudice good machine operation and long duration.

The Manufacturer denies all responsibility for accidents/injury/damage caused by negligence and the non-observation of the regulations given in this manual.

The Manufacturer is, however, at your complete disposal to guarantee technical assistance and anything that may be necessary for optimum performance and maximum return.

2.2 JET-X seed-drill components

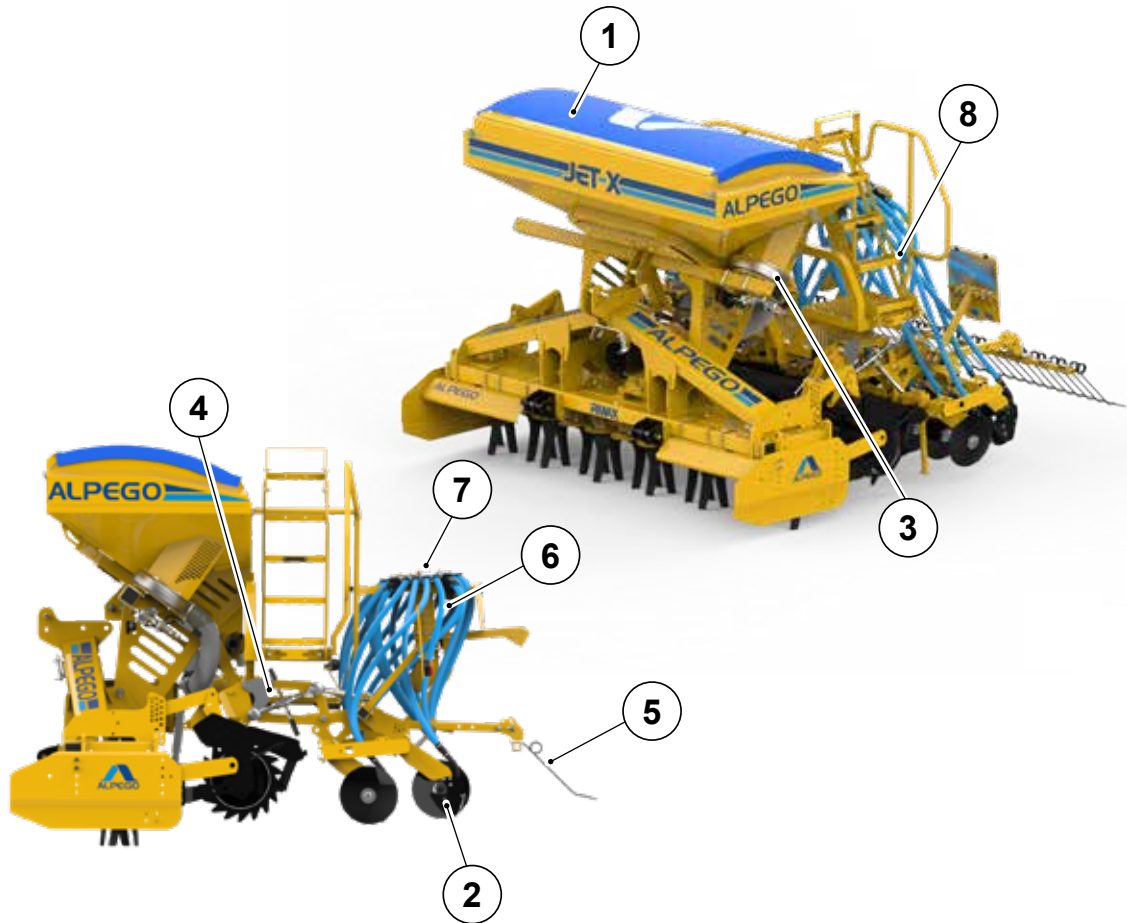

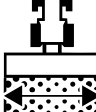
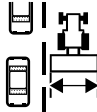



Fig. 3 JET-X Seed-Drill Components

Ref.	Description	Ref.	Description
1	Seed hopper	5	Rear seed covering harrow
2	Coulters	6	Radar
3	Fan	7	Distribution head
4	Seed bar fast connection	8	Hopper loading ladder

Tab. 2 JET-X Seed-Drill Components

2.3 Technical specifications of the machine

2.3.1 JET-X technical specifications

Model	 mm	 mm	 n°	 mm	 lt	Oil tractor capacity Lt.	 Kg
JET-X 300	3000	3000	24	125	1500	-	-
JET-X 350	3500	3500	28				-
JET-X 400	4000	4000	32				-

Tab. 3 JET-X Technical specifications

2.4 Sound level



If the tractor is equipped with a cabin, the sound level will depend on the soundproofing level of the cabin itself. If the tractor does not have a cabin or is used with the windows open, the noise level emitted by the machine while working and measured at a distance of 200 mm from the rear window exceeds 85 dBa. It is therefore advisable to use protective earmuffs as indicated in the regulations of different countries.

3 SAFETY REGULATIONS

3.1 Use in machine safety

- Read the user and maintenance manual carefully before starting to use and carry out maintenance on the equipment.
- The manufacturer cannot be held responsible for any damage caused to people, animals or things caused by the non-observance of the safety regulations.
- The seeder has to be combined with an implement (power harrow / rotary tiller / cultivator) connected to the tractor 3-point hitch and the machine has to be operated by an operator
- It is forbidden to use the machine for purposes other than those expressly indicated in this manual.
- It is forbidden for people to drive the tractor if they do not have a current driving licence, if they do not have the necessary experience, or if they are not in good health.
- Examine the stickers on the machine carefully and respect the indications they give.
- While manoeuvring, do not allow people or animals to enter the operating range of the machine.
- Do not allow people, animals or things to approach the machine while it is working in order to avoid being hit by the clods and stones that the machine ejects.
- It is forbidden to enter the area between the tractor and the machine to activate the external commands of the hydraulic lifter
- Always remain seated in the driving position of the tractor, and only come down when the tractor power takeoff is disabled and the handbrake has been activated.
- During work pauses deactivate the power takeoff, switch off the motor, position the machine on the ground and activate the tractor handbrake.
- Do not work without the protections.
- Do not allow the machine to operate loadless (i.e. while it is out of the ground).
- Do not turn sharply if the machine is embedded in the ground, and never work in reverse.
- Always raise the machine when changing direction and reversing.
- During transport, or each time the machine has to be lifted, it is advisable to regulate the tractor lifting group in such a manner as to keep the machine at a height of minimum 45 cm from the ground. Avoid using public roads if the machine is dirty with earth, grass or other things that produce dirt and can cause traffic blockage. Do not allow the machine to fall violently to the ground; instead lower it slowly to permit the gradual insertion of the blades into the earth.
- Not following the points mentioned below causes all the machine components to oscillate strongly, which compromises their integrity.
- While transporting on roads with the machine raised, lock the command lever of the tractor hydraulic lifter.
- The machine and its accessories (if present) should be equipped with suitable signals and protections when on the road.
- Do not use the machine as a means of transporting people, animals or things.

- Do not work on earth or in places that can compromise machine stability.
- Only use the drive shaft supplied by the manufacturer, which is equipped with the relative safeties against overloads.
- The cardan shaft protection should always be reliable. It should be checked periodically and fixed using the chains to prevent it from rotating.
- Always disable the Power Takeoff when the cardan shaft is at an angle of more than 15°, see figure.

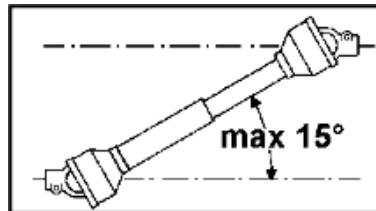

Fig. 4 Angle cardan shaft

- The seed-drill can transport chemical substances that are mixed with the seeds. Do not allow adults, children or pets to approach the seed-drill.
- No-one should approach or try to open the seed tank when the seed-drill is working or ready to be used.

3.2 Hydraulic connections

- When connecting the hydraulic pipes to the tractor hydraulic system, make sure that the hydraulic systems of the machine tool and the tractor are not under pressure.
- In cases of operational connections of a hydraulic type between the tractor and the machine tool, all plugs and sockets should be marked with colours in order to exclude errors. Should an exchange occur, the danger of accidents arises.
- The hydraulic system is pressurised. To avoid the danger of accidents, suitable auxiliary instruments should be used when searching for leaks.
- Never exceed the indicated pressure of the oleodynamic system.

3.3 Carrying out maintenance safely

- Do not allow unauthorised people to carry out maintenance or tamper with the machine in any manner.
- Maintenance and repairs should be carried out in suitably equipped workshops.
- Always use original accessories and spare parts to respect the manufacturer's requirements. Not using original parts and accessories renders the guarantee null and void and can cause function irregularities that prejudice machine safety.
- When carrying out any operation on the machine always disable the tractor power takeoff, insert the handbrake, remove the ignition key and make sure that nobody boards the tractor.

3.4 Circulating on roads

If necessary, the machine can be transported on the roads while hitched to the tractor. The operator must check, compare and adapt the implement so that it fully complies with the Highway Code in force in the country of use. Bear in mind the following recommendations:

1. Comply with the instructions in this manual when you hitch the machine to the tractor;
2. The machine must remain blocked and raised from the ground during transport;
3. Before the seed-drill is transported, it must be emptied of all the seeds. Transportation with seeds inside it could cause break-downs and change the loads on the axles of the tractor.
4. Obligation to respect the rules for the protection of one's own safety and that of others, taking all possible precautions.
5. Projecting parts and those beyond the width of the tractor must be fitted with the relative protections.
6. The entire implement must be equipped with its own lighting system complete with flashing lights and indicators.
7. Warning boards to indicate the projecting parts of the implement must be affixed where necessary.
8. The braking distance and steering capacity of the tractor are influenced by the weight of the machine hitched
9. To its power lift. When driving round bends, take great care and allow for the action of the centrifugal force that
10. Shifts the machine's center of gravity.
11. Comply with the load limits on the axles. Bear in mind the limits imposed by the overhang and projection from the sides of the tractor

3.5 Clothing

Always wear safety gear and clothes. Make sure no dangling parts are present as they may get caught in moving parts. For the same reasons please always remove watches, rings, necklaces, wristbands etc. Long hair may be a danger as well, please keep them tied.

If it is Always wear safety gear as required by your local authorities (safety shoes, gloves, earplugs, masks, etc.)



Fig. 5 Protection systems

3.6 Ecology

Respect the regulations in your country regarding the use and disposal of lubricating products, maintenance operations and machine cleaning. Carefully follow the instructions given on the packaging of the products used. Respect current standards for machine scrapping.

3.7 Safety signals

The various adhesives on the machine are there to highlight the source of danger. Observe them carefully and follow the indications for using the machine safely. The labels should be kept clean and be legible – if damaged they should be replaced



There are safety labels on the machine, which must be strictly observed by any person operating the machine.





IT IS FORBIDDEN to remove or make illegible the safety, danger and obligation signs on the machine.





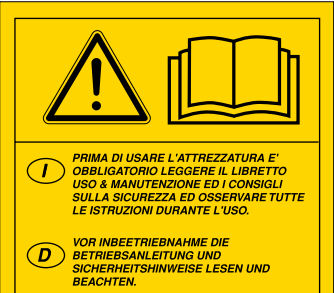

The total or partial failure to comply with the safety signs releases ALPEGO S.p.a. from any liability for damage to persons, property or animals.

Safety signs in the workplace are a measure that further improves the operators' safety conditions by providing correct information on needs and situations requiring caution and certain behaviours. The safety messages to be conveyed to operators by means of appropriate signs must comply with the provisions of the directive in force. By way of example, the most commonly used signs are shown below.

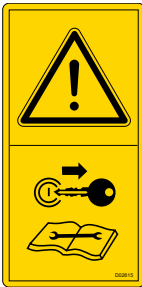
ADHESIVE LABEL	CODE	MEANING
	D02612	Before using the machine, it is mandatory to read the use and maintenance manual and the safety tips and to observe its contents during use.
	D02627	Indicates the hooking point for transporting the machine.
	D02613	Indicates the danger of shearing while the machine is working

Tab. 4 Safety signs applied to the machine

ADHESIVE LABEL	CODE	MEANING
	<p>D02609</p>	<p>It indicates the absolute prohibition to step on the machine while it is in operation.</p>
	<p>D02615</p>	<p>Indicates the need to switch off the tractor and remove the ignition key during maintenance operations</p>
	<p>D02624</p>	<p>Indicates danger caused by pressurised oil should the hydraulic pipes break. Consult the instruction manual before repairing the hydraulic systems</p>
	<p>D02614</p>	<p>It indicates the danger of crushing on the gears of the gearbox, it is recommended turning off the PTO when changing gears.</p>
	<p>Q15A00531</p>	<p>The sticker depicts the compulsory PPE (Personal Protective Equipment): overall, mask, earplugs, safety shoes, gloves</p>

Tab. 4 Safety signs applied to the machine

In the event that the plates should deteriorate or become poorly visible in general or missing, it is mandatory to replace them by requesting them directly from ALPEGO S.p.a.

ALPEGO S.p.A. declines all responsibility for any accidents or damage to persons, property or animals caused by the absence of safety plates on the machine.

4 INSTALLATION

4.1 Lifting the machine



The lifting and transport operations should be carried out using means that are suitable for the weight of the machine and by people who are trained in these types of manoeuvre. Should it be necessary to lift the machine, hook it as shown in the figure and transport it. During this operation the machine should not be lifted by more than 200 mm from the ground. To avoid damaging the sheet, use homologated tape on the first section.

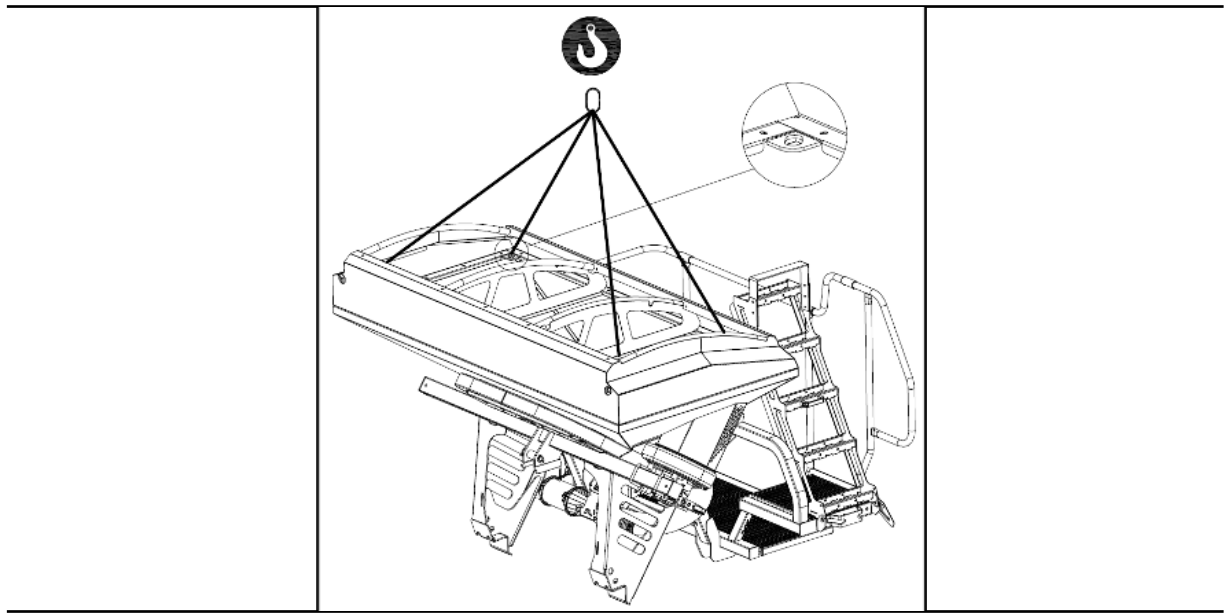

Fig. 6 Lifting the machine



It is strictly forbidden to lift the hopper from its hooks if it is combined with a specific implement (power harrow or disc harrow)

4.2 Applying the seed box fast coupling



All maintenance, adjustment and work preparation operations should be carried out while the tractor is switched off, with the ignition key out and with the seeder positioned on the ground in a stable manner on its support legs.

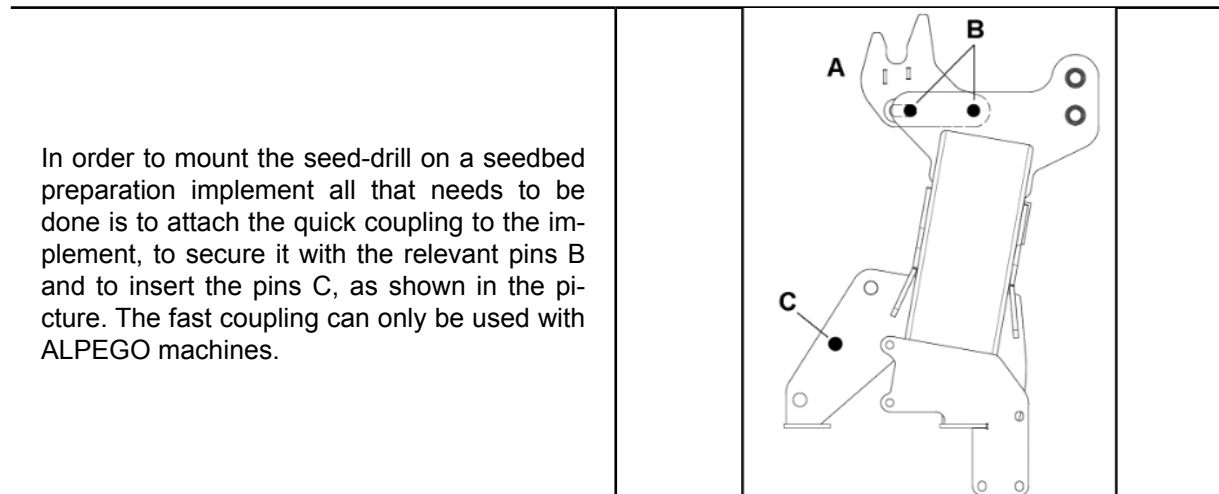

Fig. 7 Applying the seed box fast coupling

4.3 Connection of the front hopper with ALPEGO machine



The seeder is designed to be combined just with power harrows / rotary tillers / cultivators Alpego: the connection of the machines requires intervention and preventive checks on each implement. Applying things to the tractor is a very dangerous operation. Be very careful to complete the whole operation and follow the given instructions. The operation should be carried out on a horizontal surface with the seeder in a stable position and on its support legs.

Proceed as follows:

1. To use the "ALPEGO" fast coupling/uncoupling system correctly, make sure that the seeder is in a stable position on its legs at a minimum height of 1.5m from the ground, as shown in the picture (Picture 8)
2. Drive the tractor close to the seed-drill. By using the tractor lift take position vertically on the pin of the upper arm of the seed-drill (Picture 9)
3. Lift the power harrow and secure it with the pin of the upper arm of the seed drill (Picture 9)
4. After the hitching has been achieved, insert the pins D, in order to secure the seed-drill on the power harrow (Picture 10)
5. Once this operation has been completed, the seeder is mounted sturdily and safely to the harrow, therefore the support legs can be removed.

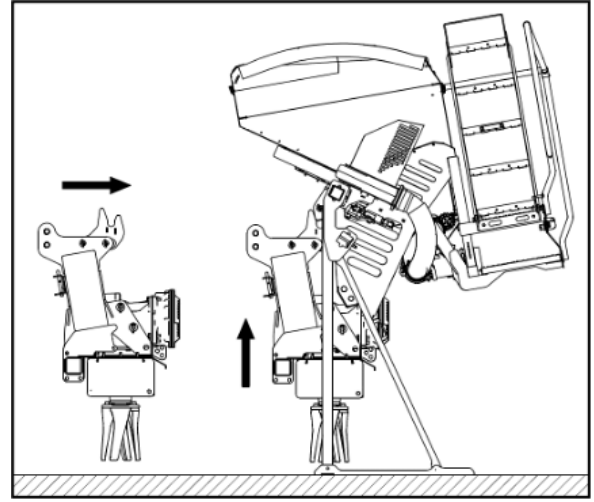
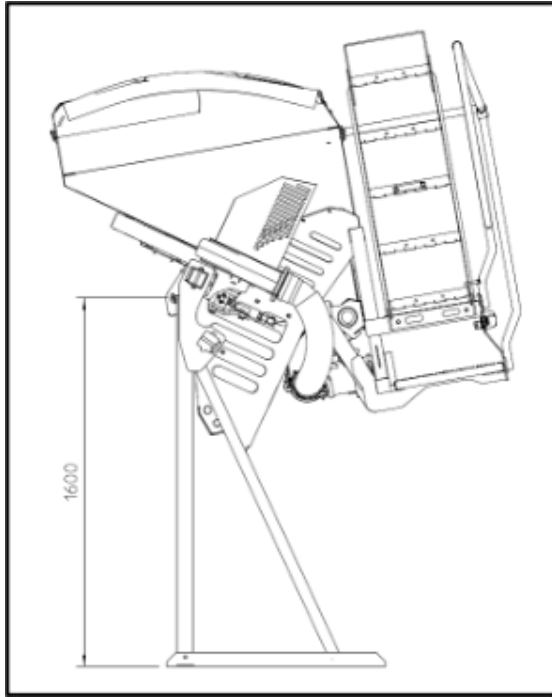

Fig. 8 Connection of the front hopper with ALPEGO machines **Fig. 9 Connection of the front hopper with ALPEGO machines**

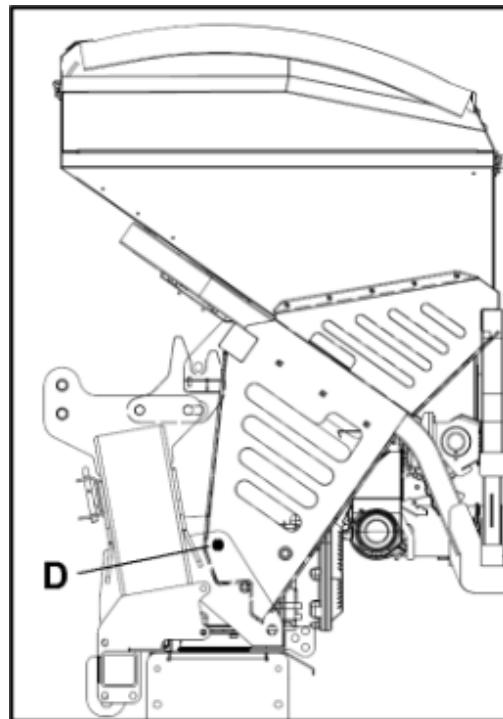

Fig. 10 Connection of the front hopper with ALPEGO machines

4.4 Connecting of seeding bar



The operation should be carried out on a horizontal surface, with the harrow in a stable position and the seed bar positioning legs inserted.

4.4.1 Installing quick hooks

In order to mount the seed-bar JET-X on a machine for soil preparation you simply have to assemble the quick hooks A, supplied standard with the seed-bar, on the rear roller.

In order to do this follow these instructions:

1. Remove the quick hooks A from the parallelograms by loosening the screws B
2. Fasten the hooks A on the rear roller by observing the mounting position of the parallelograms mounted on the seed-bar

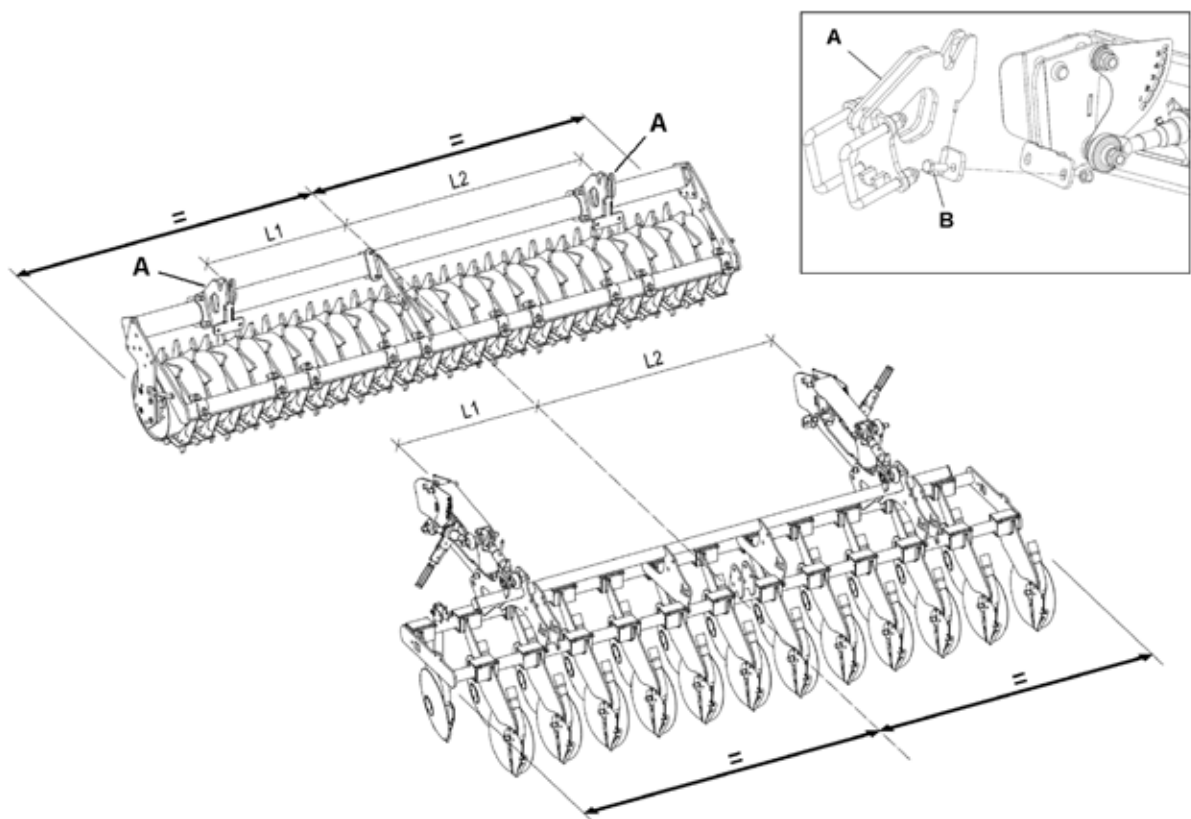

Fig. 11 Installing quick hooks

4.4.2 Assembly of the following harrow

At the time of delivery of the Seed-drill JET-X the following harrow is supplied in the shipment position.

In order to position it correctly follow this instructions:

1. Remove the pins **A** and **B**, rotate the tube with the springs (1) and, at the same time, lower the complete following harrow (2) to the ground.
2. Place again the pins **A** into 1 of the 4 holes in the bracket to prevent the rotation.
3. Rotate the lever **C** to make the assembly of the loading spring **D** easier. Make sure that the spring maintains a slight tension even in the lowest working position, so as to prevent an accidental unhooking.
4. Lift the following harrow and position the pins **B** in the perforated sections under the arms supporting the following harrow. The position of pin **B** changes the pressure of the tines of the following harrow

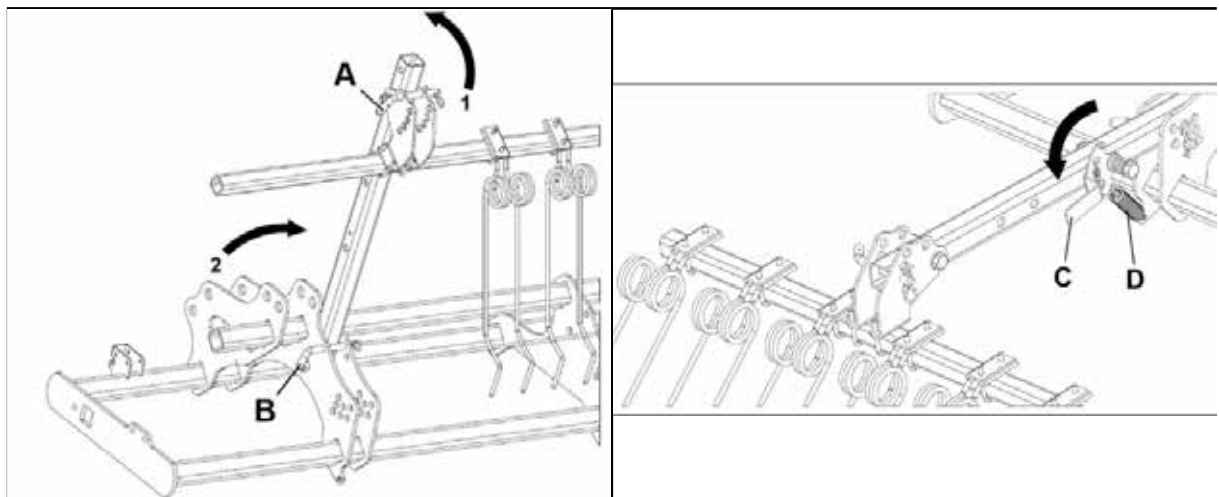

Fig. 12 Assembly of the following harrow



Never place the pins B in the holes above the supporting tube in order to stop its oscillation: while working structural damages to the arms may occur.

4.4.3 Assembly of the distribution head

At the time of delivery of the Seed-drill JET-X the distribution head is supplied in the shipment position.

In order to bring it to its correct position you simply have to rotate it from hole **A** to hole **B** and fasten it with the screw.

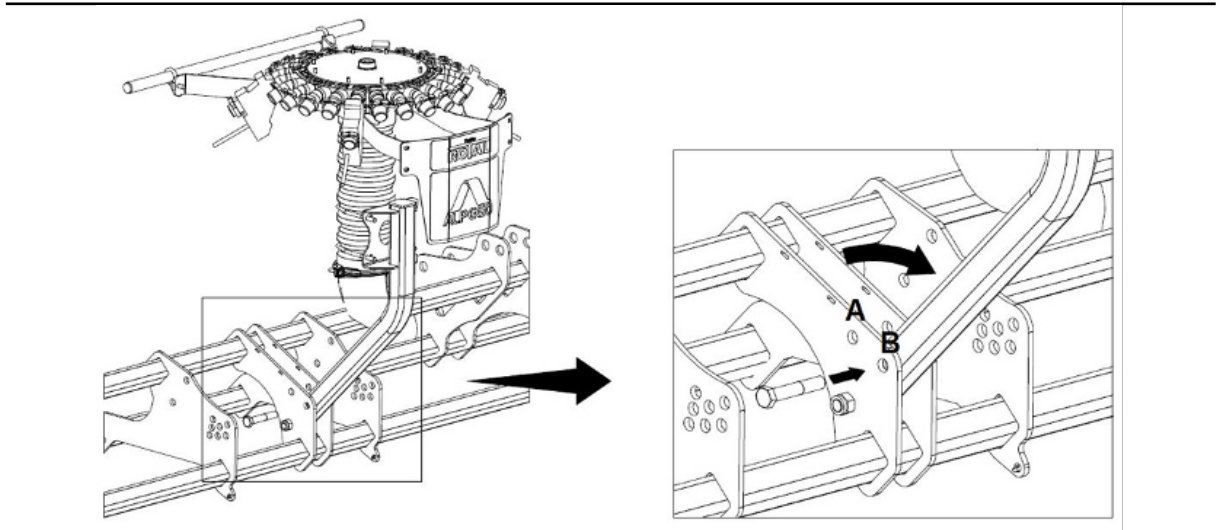

Fig. 13 Assembly of the distribution head

4.4.4 Hitching the seeding bar

Before you hitch the seed-bar, make sure the parallelograms are mounted in their correct position. The position varies depending on the type of rear roller of the machine.

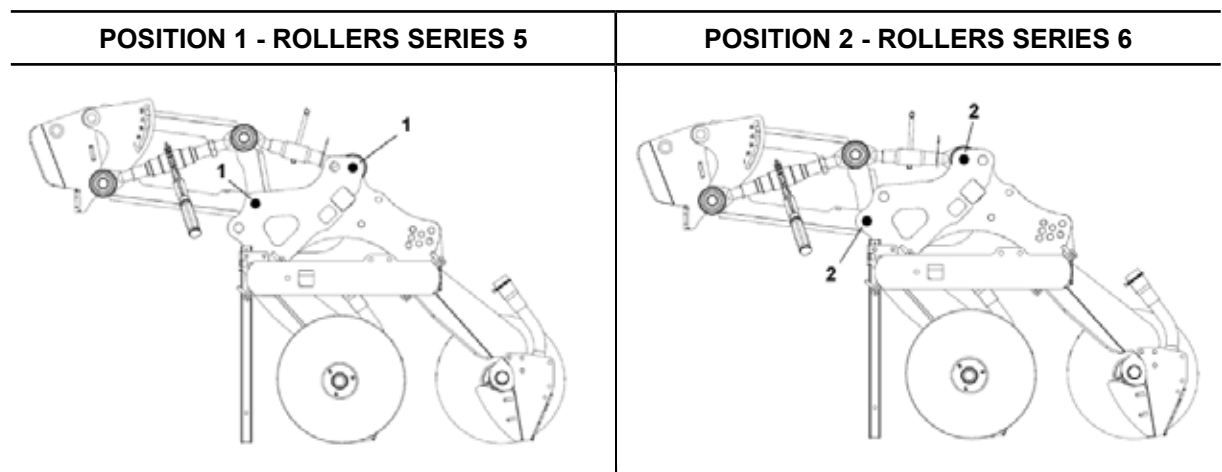

Fig. 14 Hitching the seeding bar

After the parallelograms have been mounted in their correct position, it is possible to hitch the seed-bar.

Follow these instructions:

1. In order to use correctly the “ALPEGO” hitching/unhitching method, make sure that the seed-bar is securely standing on its legs.
2. Shorten the tie-rods **A**, so as to lift the hitching holes **B** of the parallelograms.

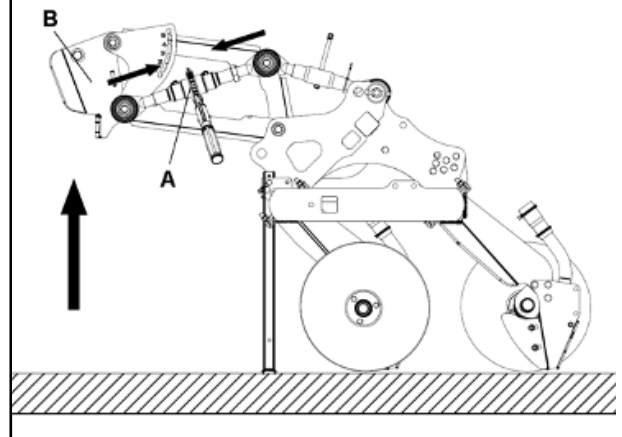

Fig. 15 Hitching the seeding bar

3. Move the machine close to the seed-bar, and be careful to fit correctly the hooks **C** into the holes **B**.
4. Lift the machine and hitch the seed-bar until you slightly lift it.
5. Once the combination has been completed, lock the quick-hitch with the screws **D**.
6. Bring the supporting legs into the working position.

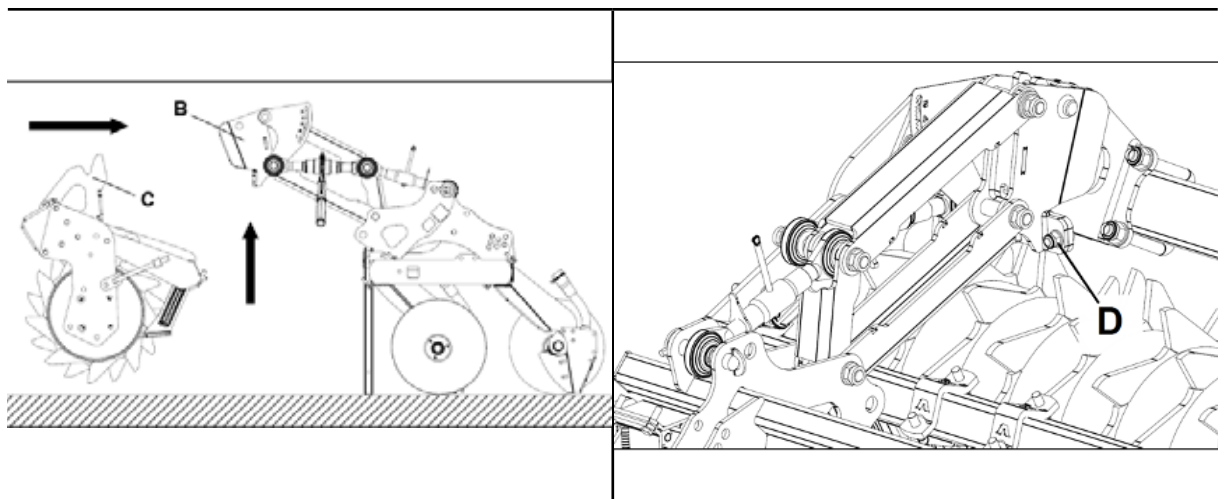

Fig. 16 Hitching the seeding bar

4.4.5 Connecting the seed-conveying hose

Inside the hopper you will find the hose for the conveyance of the seeds from the metering unit to distribution head, which is pre-assembled.

Perform the following operations for its assembly:

1. Loosen the hose clamp with screw **A** at the end of the hose
2. Fasten the end 1 on the corrugated hose of the distribution head with the hose clamp **A**
3. Loosen the quick-release hose clamp **B** from the end 2 of the hose
4. Fasten the end 2 on the hose going out of the metering unit by means of the quick-release hose clamp **B**

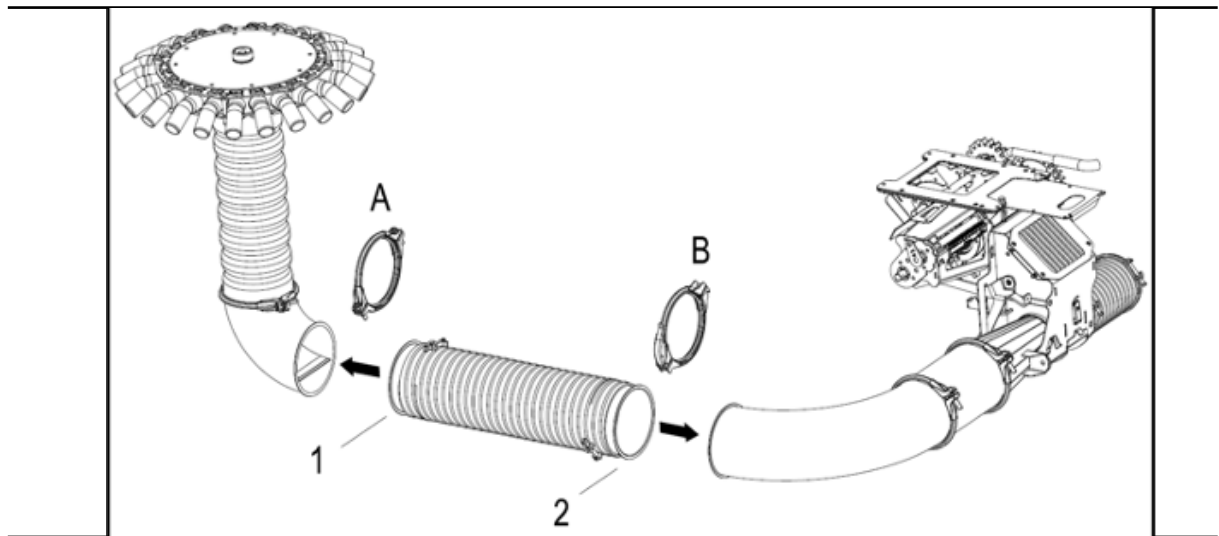

Fig. 17 Connecting the seed-conveying hose



Do not connect the flexible hose with the seeder bar or with the seed-drill by means of hose clamps or other means. The motions of the seeder bar or of the rear roller could cause break-downs or the detachment of the hose.

4.5 Assembly of the rear lights

When the seed-drill JET-X is delivered, the plates with the rear lights and their supports are supplied unassembled and they are to be found inside the hopper. The electric wiring is already in place on the seeder-bar. To assemble the rear lights proceed as follows:

1. Place the two supports **A** on the two ends of the upper tube of the seeder-bar and fasten them by means of their U-Bolts
2. Mount the plates **B** on the supports
3. Connect the electric wires of the lights with the already assembled electric wiring on the seeder-bar.

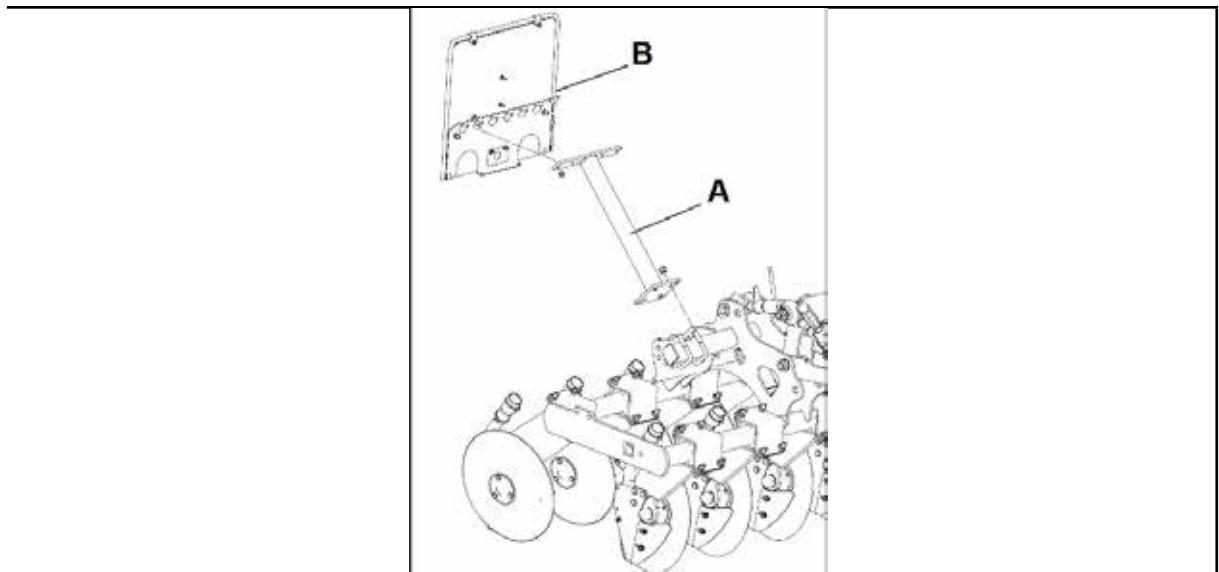

Fig. 18 Assembly of the rear lights

4.6 Electric wiring of the seeder bar

All the electronic elements on the seeder-bar (rear lights, radar, GPS, tramline...) have their electric wiring already assembled standard on the seeder-bar.

In order to connect the electric wiring of the seeder-bar with the electric wiring of the seed-drill all you need to do is to plug in the electric plugs into their respective sockets which are to be found on the connecting plate **A**.

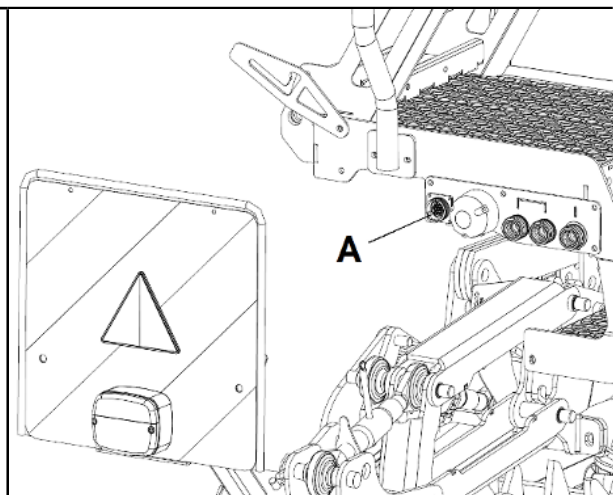

Fig. 19 Electric wiring of the seeder bar

4.7 3-point switch

This device can interrupt the rotation of the metering unit's seeding shaft when the tool is lifted; it is in fact fitted at the third point.

With the third point mounted, perform these operations:

1. Place flange **A** on pin **B**; screw **C** must be aligned with the pin.
2. Insert screw **C** through flange **A** and then through bracket **D**, which, depending on the category of the third point pin, requires reducers **F** ($\varnothing 26\text{mm} - \varnothing 32\text{mm}$) to be fixed on the bracket; then, assemble component **D**, which must be centred on the third point pin and secured with handle **E**.
3. Attach flange **A** to the third point of the power harrow using the category-specific (2nd - 3rd - 4th) reducers **G** to be inserted into the holes in the attachment plates.
4. Lock the assembly with countersunk washer **H** and screw **L**.
5. Assemble microswitch **M** on bracket **D** and fix it with screws **N** so that the flexible rod passes through the slot.
6. Electrically connect microswitch **M** by connecting cable **N** to the dedicated connector "X" on the control unit.

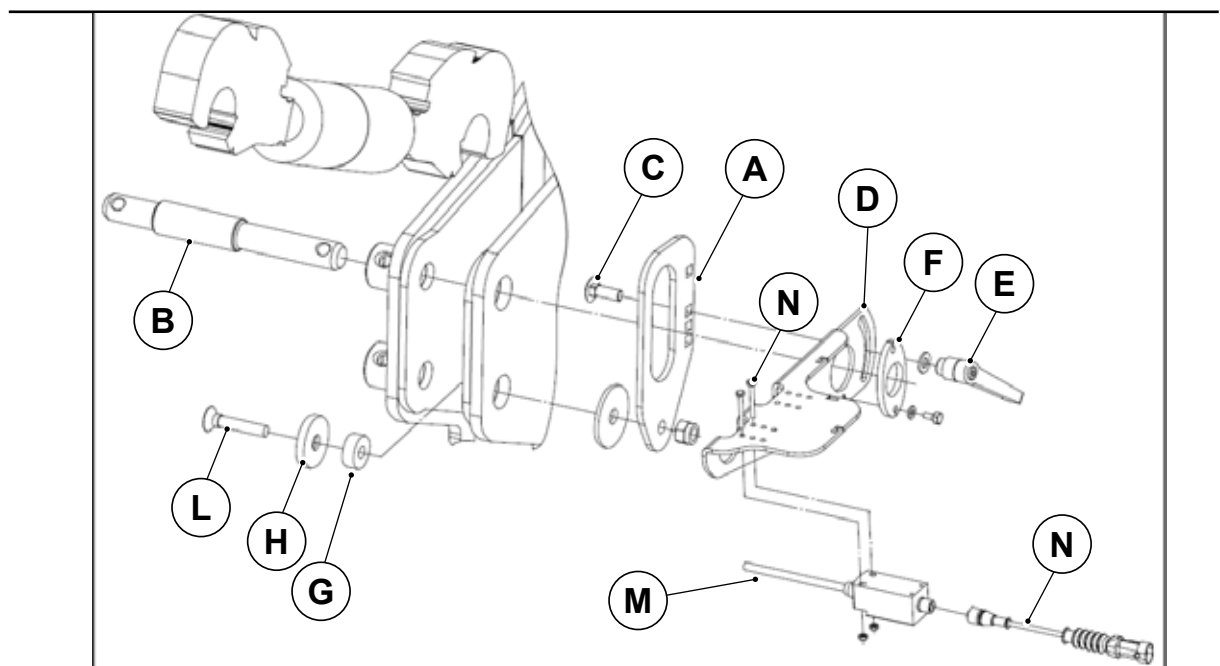

Fig. 20 3-point switch

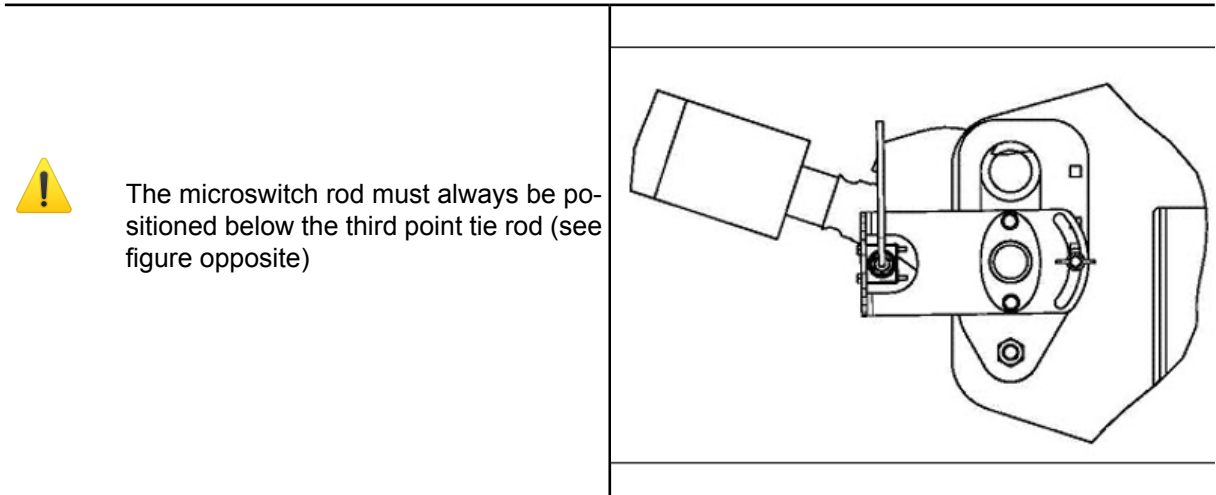

Fig. 21 Microswitch rod

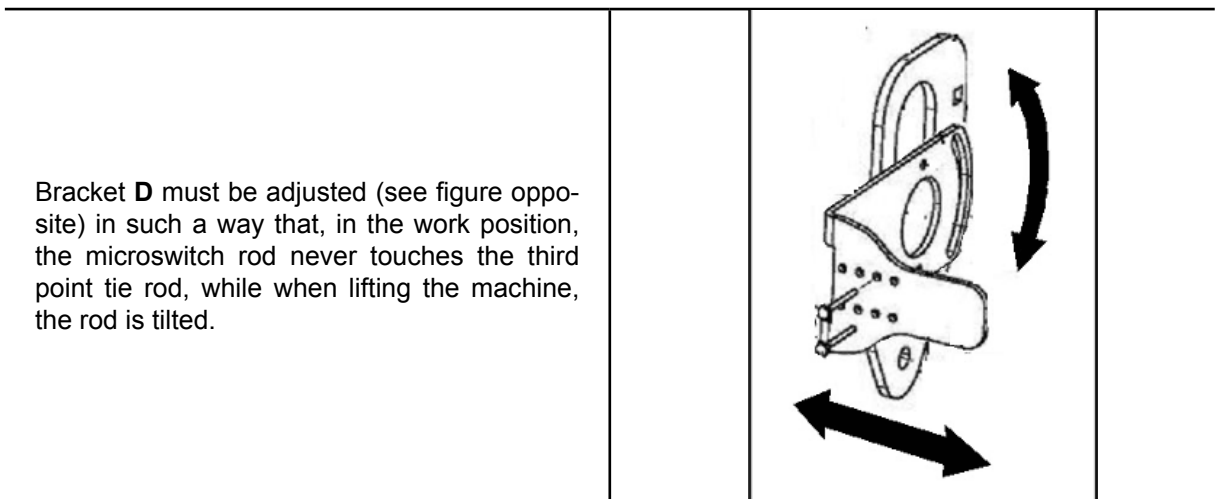

Fig. 22 Microswitch bracket

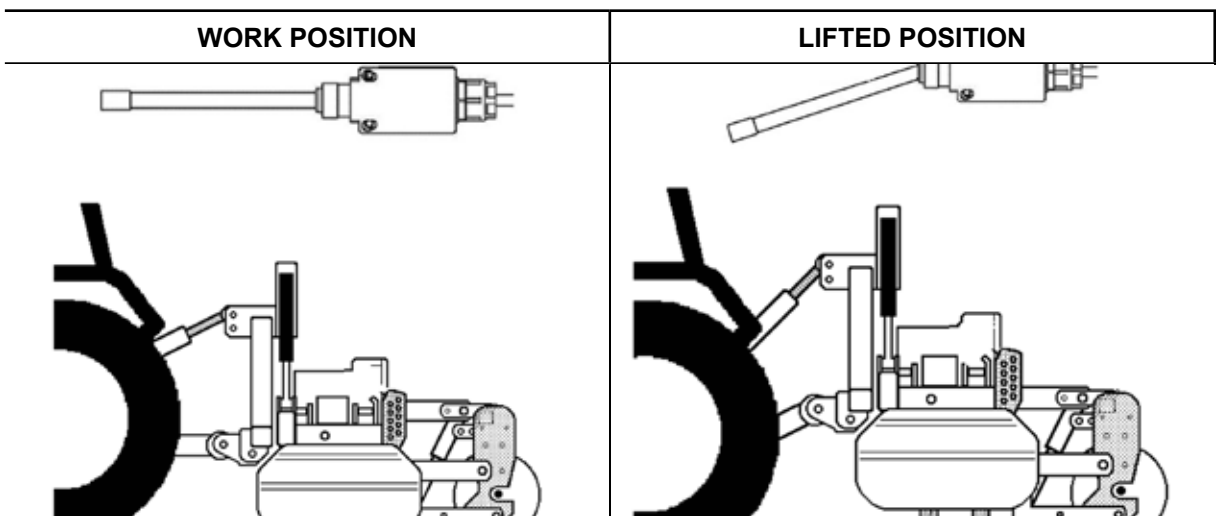

Fig. 23 Work position

Fig. 24 Lifted position

Checking the raising capacity and tractor stability



When a machine comes coupled to the tractor, becoming to the ends of the street circulation integrating part of the same one, can alter of the stability and cause difficulty in the guide and the job.

The application of a machine to the tractor, involves one various distribution of the weights on the axes. Depending on the composition of the machine, it is therefore advisable to add ballast to the front part of the tractor so as to adequately distribute the weight on the axes.

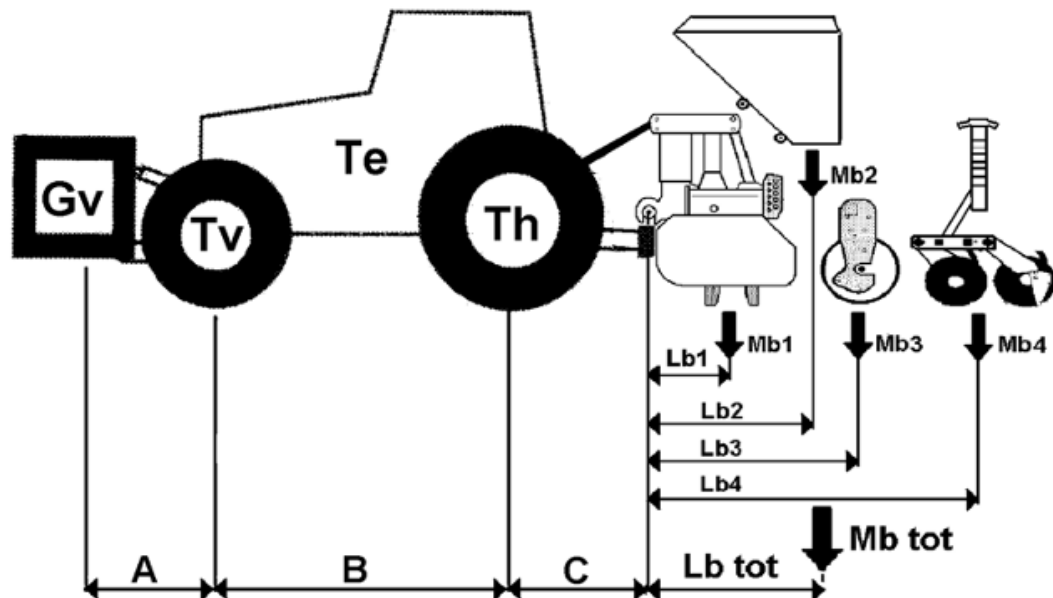

Fig. 25 Checking the raising capacity and tractor stability

Refer to the following list:

A=	Distance of the front axle from the front ballast (m)	1
B=	Tractor wheelbase (m))	2
C=	Distance of the rear axle from the implement's lower hitch (m)	2
Gv=	Ballast weight (kg)	3
Te=	Empty weight of the tractor	2
Tv=	Load on the tractor's front axle when empty	2
Th=	Load on the tractor's rear axle when empty	2
Lb tot=	Distance from the lower hitch to the center of gravity of the complete implement combination (m)	3
Lb1=	Distance from the lower hitch to the center of gravity of the first combi machine (m)	1
Lb2=	Distance from the lower hitch to the center of gravity of the second combi machine (m)	1
Lb3=	Distance from the lower hitch to the center of gravity of the third combi machine (m)	1

Lb4=	Distance from the lower hitch to the center of gravity of the fourth combi machine (m)	1
Mb1=	Overall weight of the first implement (kg)	4
Mb2=	Overall weight of the second implement (kg)	4
Mb3=	Overall weight of the third implement (kg)	4
Mb4=	Overall weight of the fourth implement (kg)	4
Mb tot=	Overall weight of the entire combi machine (kg)	2

1 = Must be measured

2 = Consult the tractor's operation and maintenance manual

3 = Must be calculated

4 = Consult the operation and maintenance manual of the required implement

The ballast to add is calculated with the formula:

$$Gv \text{ min.} = \frac{(Mb \text{ tot} \times (C + Lb \text{ tot})) - (Tv \times B) + (0,2 \times Te \times B)}{A + B}$$

The distance from the center of gravity of the combi machine to the lower hitch of the tractor is calculated with the formula:

$$Lb \text{ tot} = \frac{(Lb1 \times Mb1) + (Lb2 \times Mb2) + (Lb3 \times Mb3) + (Lb4 \times Mb4) + (Lb... \times Mb...)}{Mb1 + Mb2 + Mb3 + Mb4 + Mb...}$$

The overall weight of the entire combi machine is calculated with the formula:

$$Mb \text{ tot} = Mb1 + Mb2 + Mb3 + Mb4 + Mb...$$

<p>On the front bridge of the tractor it must, in any case, burden at least 20% of the total mass tractor-tool in march order. It is however to hold present that, beyond to the appropriated one chosen the connection tractor-tool, the application of ballasts in front position, the limits and with the modalities indicated from the constructor of the tractor, can improve of the stability. Moreover, with firm tract or it must be made to come down to earth the toolavoiding therefore possible involuntary reductions, improving some, at the same time, the stability.</p>	Tractor wheelbase:	B = m
	Distance of the front axle from the front ballast:	A = m
	Tractor weight:	Te = Kg
	Ballast weight:	Gv = Kg
	Load on the tractor's axle when empty:	Tv = Kg
	Implement weight:	Mb tot = Kg
	Tot center of gravity length:	Lb tot = Kg

5 USER INSTRUCTIONS

5.1 Oleodynamic blower movement



The equipment is only suitable for the uses that are indicated. Using the machine for other purposes can damage it and endanger the machine operator.

Use the equipment correctly and carry out maintenance regularly to keep the machine working correctly. Follow instructions scrupulously to avoid problems that could prevent good machine operation and duration. Users must follow the instructions given in this manual because the Manufacturer cannot be held responsible for any damage or injury caused by negligence and non-observance of such instructions. The oleodynamic movement of the blower must be used, kept and repaired by personnel who know the machine perfectly and the relative dangers. Make sure that the quick couplings are connected correctly. If they are not, the system components can become damaged. Disconnect the oleodynamic connections only after depressurising them.



Consult a doctor immediately if pressurised oil leaks come into contact with the skin. This kind of injury can lead to serious infections. It is totally FORBIDDEN to install oleodynamic components in the tractor cabin.

5.1.1 Hydraulic connection with the tractor

Check in the Owner's Manual of the tractor its hydraulic features, which must be as follows:

- Hydraulic system of the "CLOSED CENTER" (also called LOAD SENSING)type
- Pump with variable displacement
- Oil delivery exceeding 100 l/min. the hydraulic operation requires 45 l/min.
- Working pressure: up to 18 0 Bar
- Oil cooling: should the tractor not be equipped with an adequate cooling system it is necessary to install one
- The tractor must be suited to receive a free-return flow connector (NO COUNTERPRESSURE)

The oil flow necessary to drive the blower is taken from the tractor hydraulic distributor, through a **delivery hose ½ A**.

The rotation speed of the hydraulic motor, and therefore the blower, is connected to the oil flow adjustable from the tractor's controls.

The hydraulic motor has a security system with a safety valve which makes it possible for the device to keep on turning by inertia even after the system has been shut off or a sudden break down of the system has occurred.

The pression gauge (0-10 bar) on the hydraulic valve allows to check the backpressure value.

For a correct performance it is important to connect the flow **discharge hose ¾ G** of the hydraulic motor to a free flow discharge plug of the tractor; this free discharge cannot present any counter-pressure exceeding 2 Bar.

The manometer **C** on the unloading checks these backpressures.

This connection is of basic importance above all to protect the hydraulic seals of the motor, which, if damaged, would allow very dangerous oil leaks.

- A) Quick coupling on the delivery side $\frac{1}{2}$
- B) Motor
- C) Manometer backpressures on unloading
- D) Quick coupling on free-flow discharge $\frac{3}{4}$
- E) Free-flow discharge

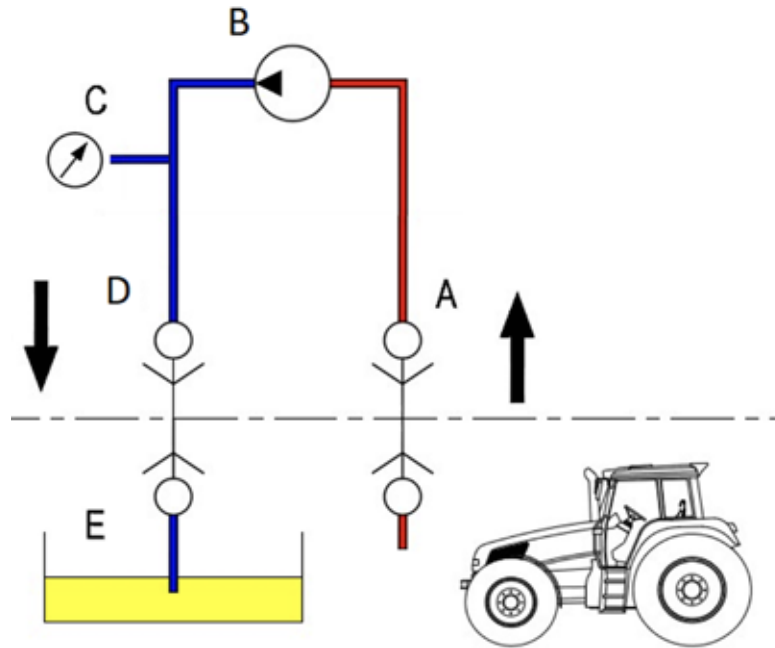

Fig. 26 Hydraulic connection with the tractor

5.1.2 Starting

With the motor off and the tractor locked, connect all the fast couplings correctly.

1. $\frac{1}{2}$ Fast coupling (A) for delivery to one of the hydraulic distributors having priority flow.
2. $\frac{3}{4}$ Fast female coupling for return (G) to the free exhaust ensuring the absence of counter-pressures above 2 bar.

Start the tractor and run the system at minimum for a few minutes, taking the constant pressure around the whole circuit in order to avoid blower instability. Only when the oil has reached an optimum pressure and there are no more blower speed jumps can the pressure be regulated. If the equipment is used with different tractors and subsequently different distributors and different oils, the setting procedure should be repeated for every tractor.

In tractors with variable capacity pump having oil capacity regulators, Starting with a small oil capacity, gradually open the internal regulator until the best working pressure MAX 150 Bar is indicated on the gauge.

5.1.3 Oil cooling

When using this type of system check the tank capacity and if there is an oil cooling system that is suitable for keeping the internal circuit temperature constant. If necessary, have your retailer install an oil radiator.

5.2 Distribution

The metering unit, which is the main organ for the performance of the seed-drill, is positioned under the seed-hopper and it is driven by an electric motor

On the basis of the setting fixed using the command **B**, the doser star wheel **A** distributes the correct quantity of seeds to the "Venturi" type ejector **C**.

The air flow generated by the fan **D** and regulated by the throttle valve **E** transports the seed to the head of the distributor at the end of the "Venturi" tube. From here the seeds are taken to the coulters and then sown. The doser can work seeds of sizes from 1 to 10 mm, and the following can mainly be sown:

- Cereals: wheat, barley, oats, rye, triticale, sorghum, rice
- Large seeds: corn, peas, beans, soy
- Minute seeds: grass, clover, colza

For the correct use of the distribution organs, please consult their special owner's manual

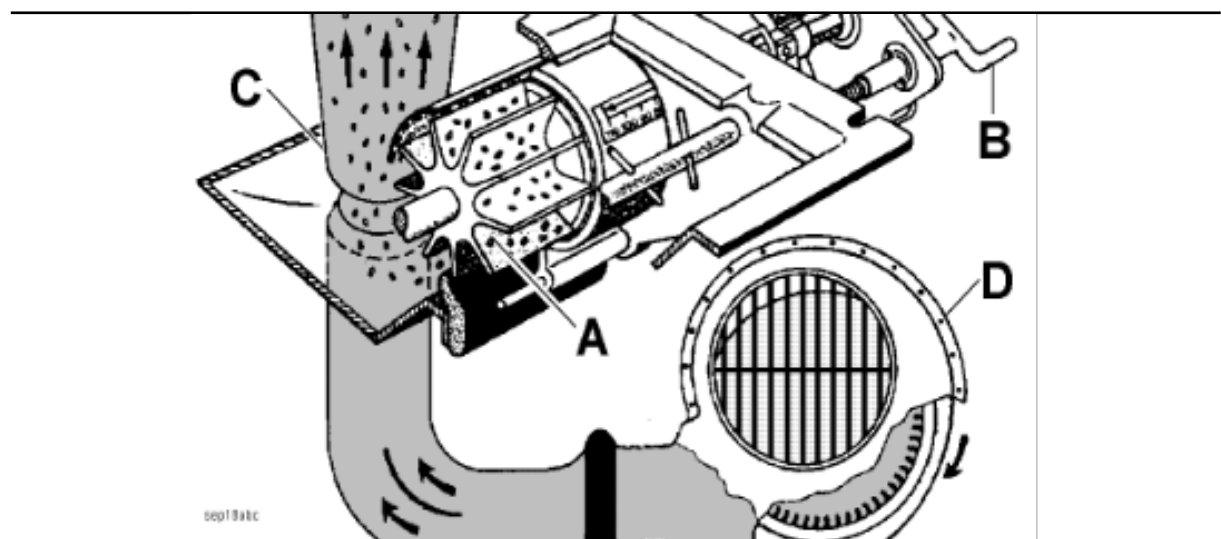

Fig. 27 Distribution

5.3 Adjustment of the following harrow

You can change the impact angle of the spring blades by changing the position of the arms in one of the 4 holes **A**.

The working pressure of the spring tines of the seed covering harrow can be varied using the pins **B**.

The height of the following harrow can be varied by means of the pins **C** in the perforated sections under the arms supporting the following harrows.

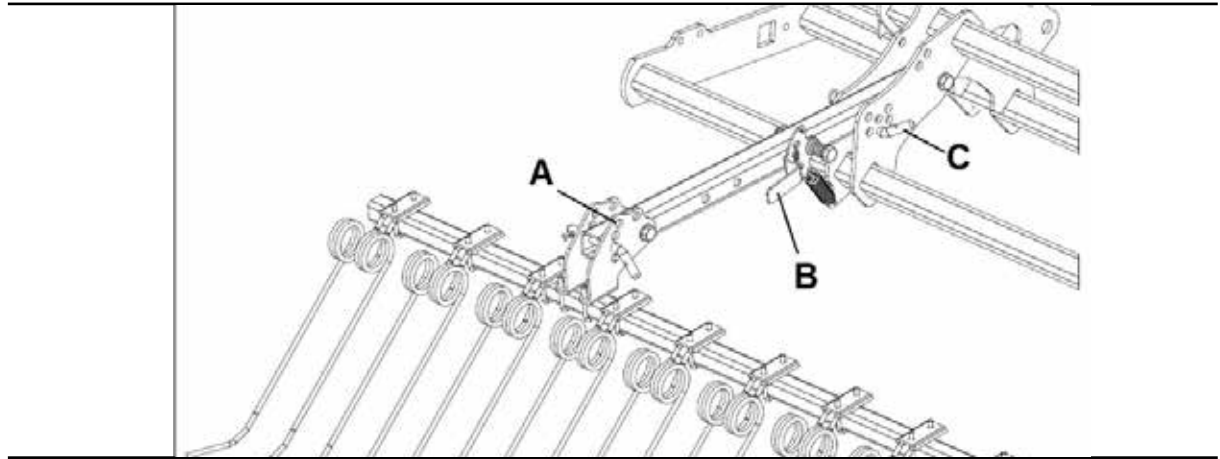

Fig. 28 Adjustment of the following harrow



NEVER put the pin **C** into the holes over the supporting square pipe to stop oscillation. Doing this can structurally damage the arms while the machine is working.

5.4 Regulating the sowing depth

Before setting the seed-drill, it is essential that you adjust the power harrow or the tiller in its working position, to check the correct sowing depth.

Once you have done this, you can adjust the seed bar depth by lengthening or shortening the tie-rod **A**. If you act on the tie-rod **B** you modify the angle of the disc bar.

Thanks to the super elastic joint, the pressure on the coulters remains constant along the whole bar, and only the height from the ground is adjusted.

Regulate the height of the tractor lifting arms so that the seed-drill does not touch the ground while it is being transported.

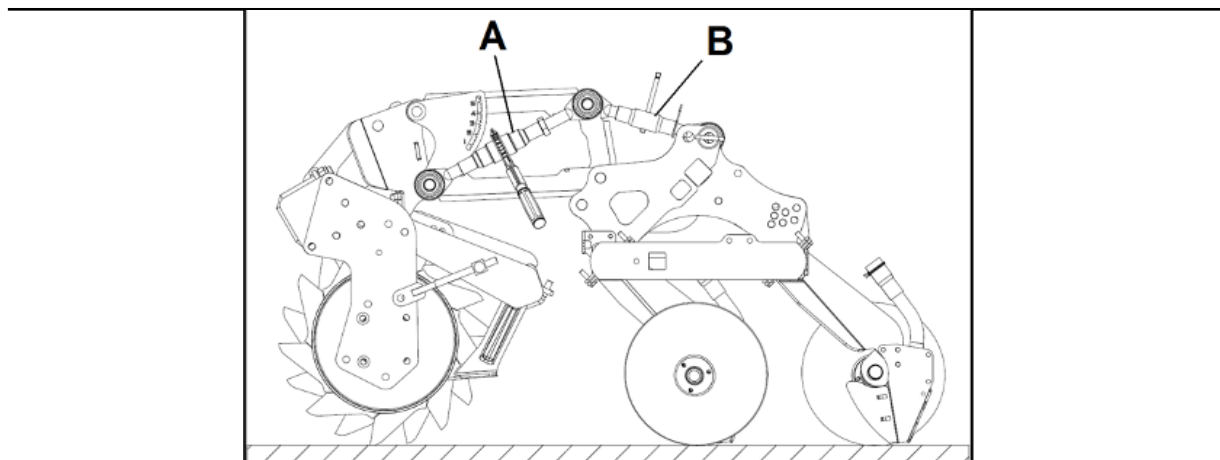

Fig. 29 Regulating the sowing depth

5.5 Adjustment of the coultter-disc scraper

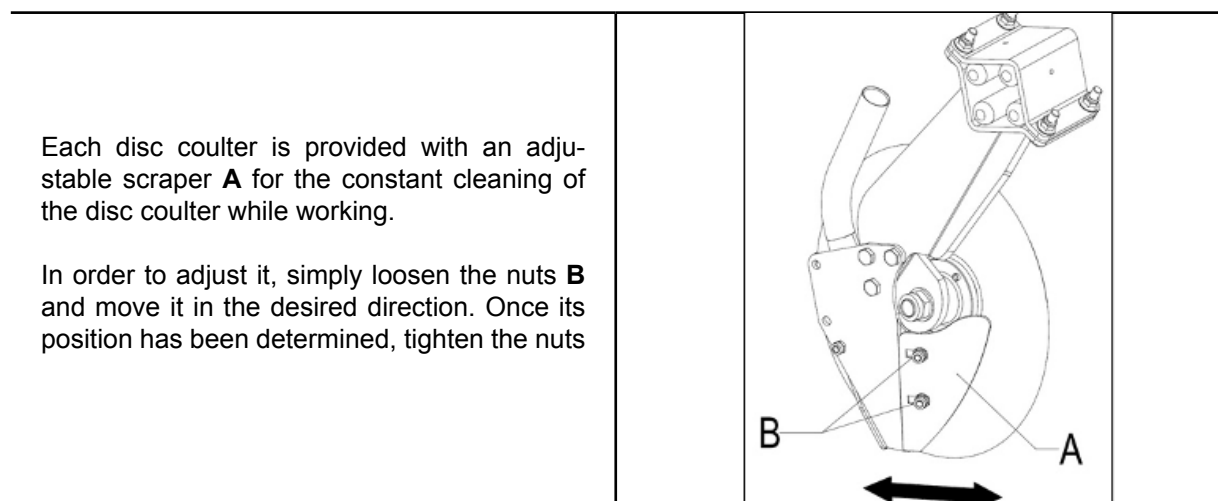

Fig. 30 Adjustment of the coultter-disc scraper



Never let the scraper rest against the disc coultter, because that could either slow or block it. Maintain a minimum distance of at least 2 mm. between the scraper and the disc.

5.6 Unhitching the seed-drill



The unhitching of the seed-drill is a dangerous operation. Perform the entire operation following the relevant directions very carefully. For a safe unhitching of the seed-drill it is important to operate on a flat horizontal surface.

5.6.1 Unhitching the seeder bar

1. Remove all hydraulic and electric connectors from the connection plate A
2. Disengage the seed-conveying hose from the seed-drill by removing the quick release hose clamp B
3. Lift both power harrow and seed-drill to a max. height of 200 mm.
4. Stop the engine and get down from the tractor
5. Lower the supporting stand of the seed-bar
6. Shorten the tie rods C in order to lower the seeder-bar
7. Remove the tightening screws D
8. Get back on the tractor and carefully lower the seeder-bar to the ground. It will disengage itself automatically from the quick couplings E
9. At this point the seeder-bar will be disengaged and it will be possible to unhitch the hopper.

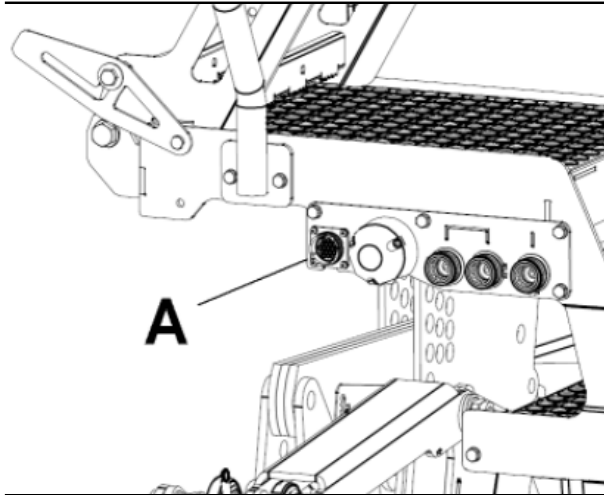

Fig. 31 Unhitching the seeder bar

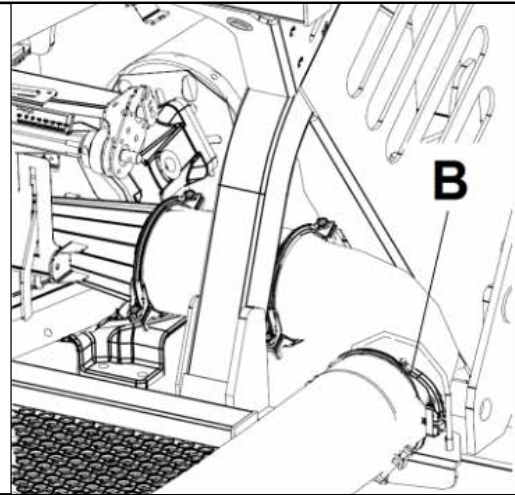

Fig. 32 Unhitching the seeder bar

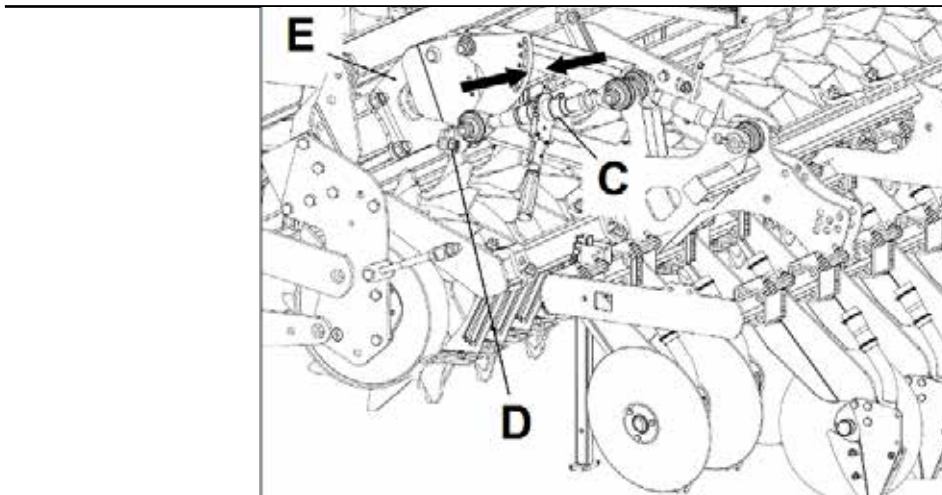

Fig. 33 Unhitching the seeder bar

5.6.2 Unhitching the hopper

1. Remove all hydraulic and electric connectors activating the seed-drill.
2. Lift the implement at such a height as to be able to insert the supporting stands supplied together with frame of the seed-drill
3. Stop the engine and get down from the tractor
4. Insert the extension tubes **F** inside the tube of the frame and secure them with the pins **G**
5. Insert the stands **H** and secure them with the pins **I**
6. Remove the securing pins **L** from the seed-drill
7. Get back on the tractor, carefully lower the stands of the seed-drill to the ground and unhitch it from the implement.

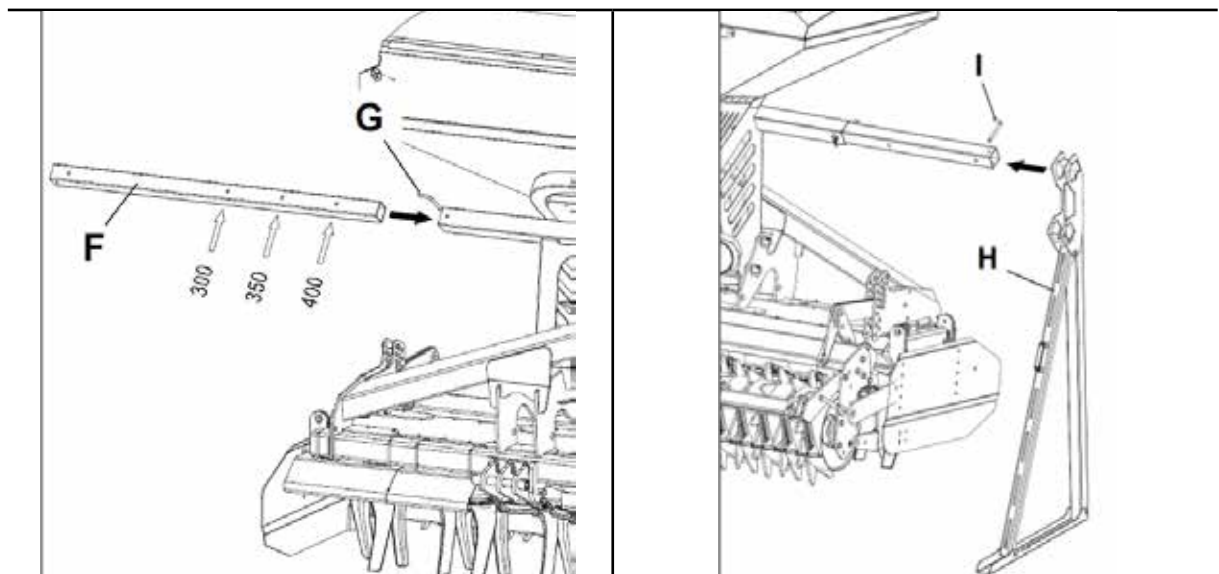

Fig. 34 Unhitching the hopper

Fig. 35 Unhitching the hopper

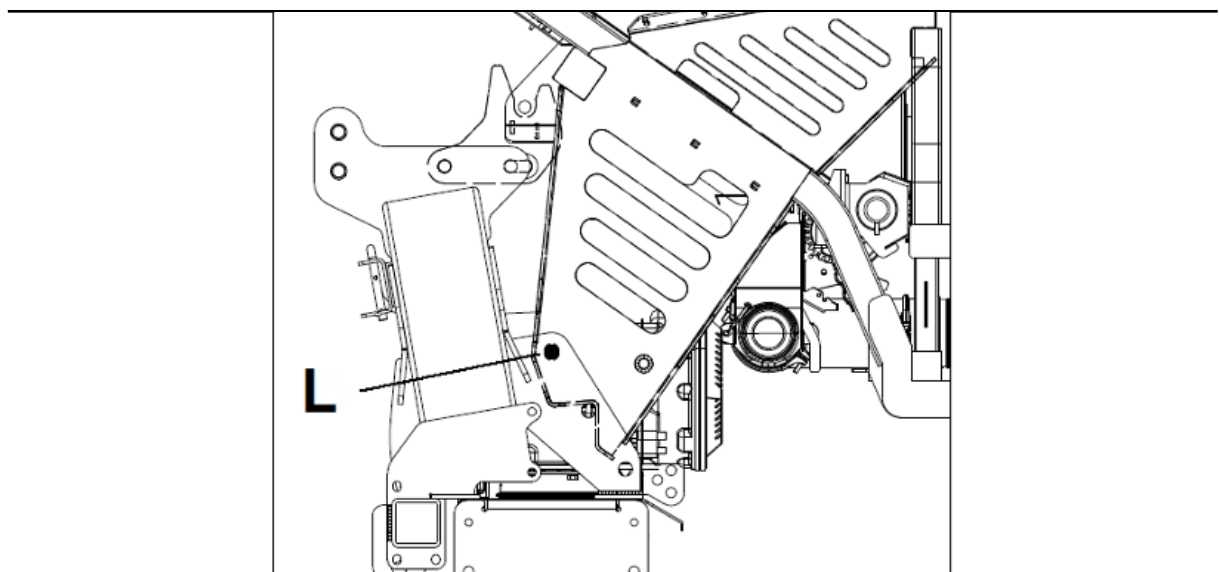





Fig. 36 Unhitching the hopper

6 MAINTENANCE

6.1 Checks and controls

During the first 8 working hours it is a good idea to check that all bolts are tight, because the force generated while working creates structure adjustment. If necessary, tighten as indicated in the table. Every 50 working hours, check the tightness of the coulters and the springs of the seed covering harrow.

			8.8 (Nm)	10.9 (Nm)	12.9 (Nm)
13	M 8	1.25	25	37	44
		1.00	27	40	47
17	M 10	1.50	50	73	86
		1.25	53	78	91
19	M 12	1.75	86	127	148
		1.25	95	139	163
22	M 14	2.00	137	201	235
		1.50	150	220	257
24	M 16	2.00	214	314	369
		1.50	229	336	393
27	M 18	2.50	306	435	509
		1.50	345	491	575
30	M 20	2.50	432	615	719
		1.50	482	687	804
32	M 22	2.50	502	843	987
		1.50	654	932	1090
36	M 24	3.00	744	1080	1240
		2.00	814	1160	1360

Tab. 5 Checks and controls (Nm)

6.2 Lubrication



Always read the warnings given on the containers carefully. Always keep oils and greases out of the reach of children. Avoid contact with the skin. Wash hands well after using these products. Treat used oils in conformity with current antipollution laws.

When starting the equipment for the first time, check and if necessary lubricate the following components:

INTERVAL H=HOURS	OPERATION
every 8/10 working hours	-Grease the tie rod greasers -Grease the row marking disc greasers

Lubrication should be increased if the machine is being used in heavy duty conditions.

6.3 Emptying the seed from the hopper

In order to remove the seeds from the hopper it is necessary to:

1. Connect a flexible hose having a diameter of 70mm. with the outlet hose A
2. Position a container under the end of the flexible hose
3. Loosen the hand-wheel B
4. Open the outlet shutter by means of the handle C
5. Discharge the seed product completely
6. Once all the seeds have been discharged close the shutter.

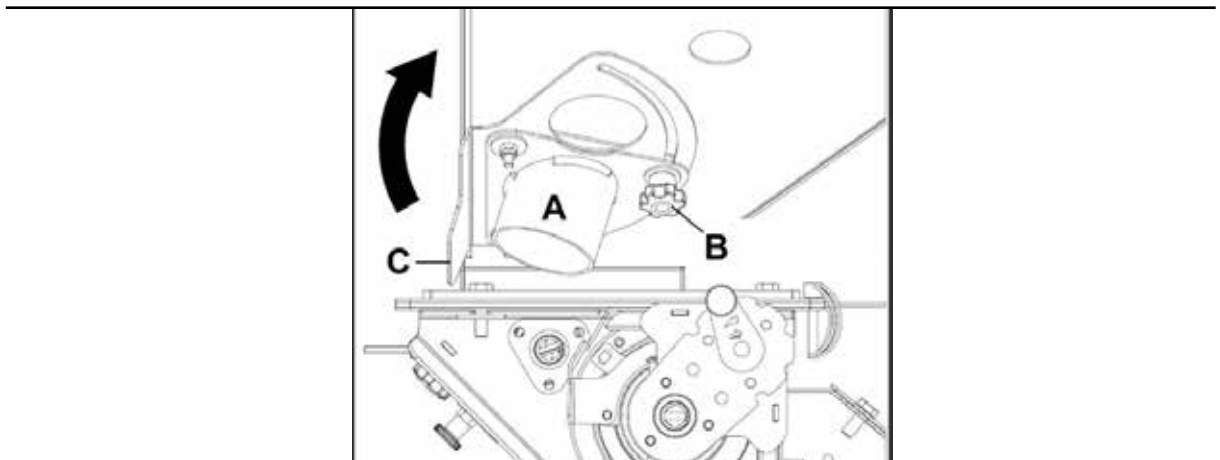

Fig. 37 Emptying the seed from the hopper

6.4 End of season operations

At the end of the season or if the equipment is not to be used for a long period of time, it is advisable to:

- Carefully remove all the seeds from the hopper and the distribution organs
- Wash the equipment with plenty of water, in particular the tank, then dry it.
- Accurately check and if necessary replace any damaged or worn parts.
- Tighten all screws.
- Place a layer of lubricant on all unpainted parts.
- Protect the equipment with a sheet of cloth.
- Place the equipment on a dry, flat surface and keep it out of the reach of unauthorised people.

It goes to your advantage if you find the machine ready for use the next time.

7 ACCESSORIES

7.1 Row marking

The row marker is a device that traces a reference line parallel to the run of the tractor on the ground. When the tractor has finished its run and inverted its direction, it proceeds along the reference line with half of the tractor track. In this manner the sowing rows are allotted equally.

- Position the row marking discs in a more or less oblique manner to obtain a sufficiently deep track, even with hard ground.
- The length of the disc arm should be equal to half of the width of the machine.
- When the running direction is inverted, the row markers should be moved using the manual electric/hydraulic command

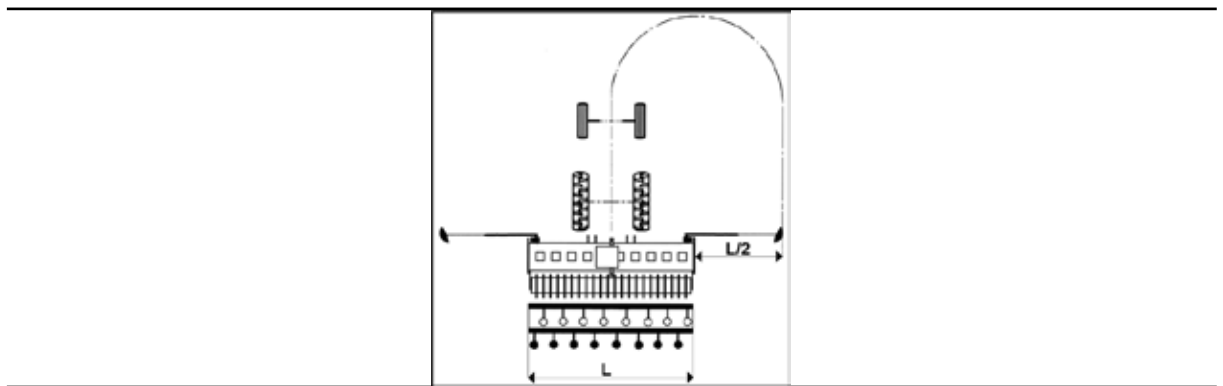

Fig. 38 Row marking

7.2 Pre-sprouting discs

The pre-sprouting discs trace two reference lines in correspondence with the coulter, to which seed exclusion solenoid valves are applied.

They can only be used with the Plus models because they are directly managed by the supplied computer. This device allows the user to treat the sown ground without treading on it.

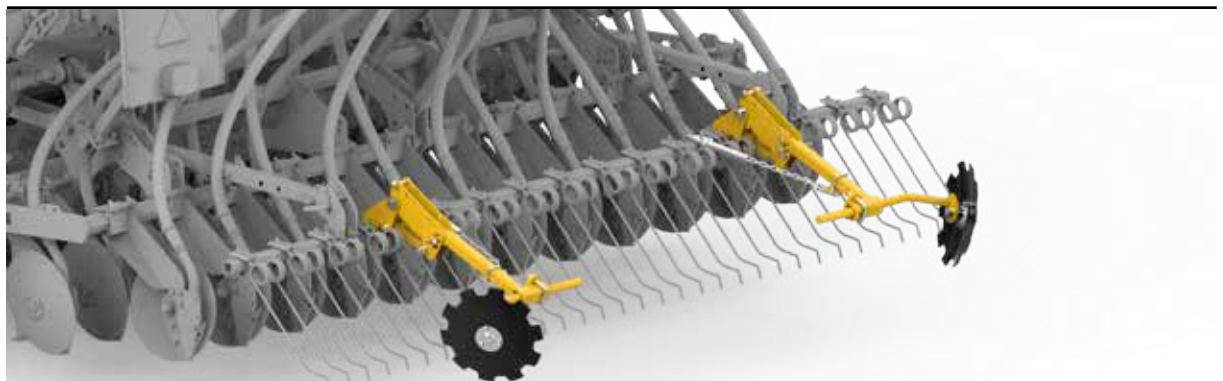

Fig. 39 Pre-sprouting discs

7.3 Hydraulic seeding exclusion

This device excludes sowing by raising the bar from the ground.

This is possible thanks to the use of two hydraulic cylinders which replace the lower arms of the parallelograms supporting the seed-bar.

With this accessory, the ground can be worked without sowing.



Fig. 40 Hydraulic seeding exclusion

7.4 Press wheel

The Press Wheel allows to precisely control the seeding depth for each single disc coulters (cannot be used with Suffolk coulters).

Thanks to the easy adjustment system it is possible to accurately set the seeding depth.



It is strongly advisable to use the press wheels on soft soils in order to avoid an excessive seeding depth. Not to be used in hard soils.



Not to be used in rocky soils.



The wheels must be in contact with the soil only when the tractor is driving straight. When turning or maneuvering the SEEDING BAR MUST BE LIFTED.

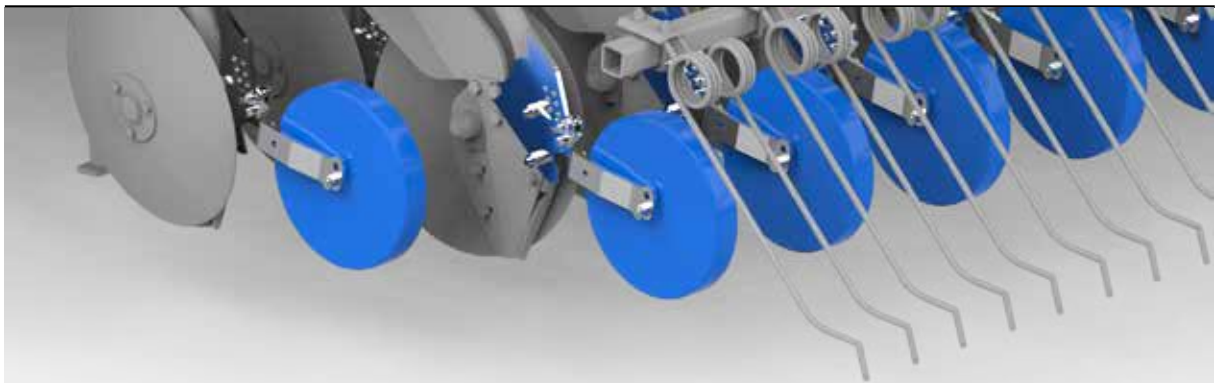

Fig. 41 Press wheel

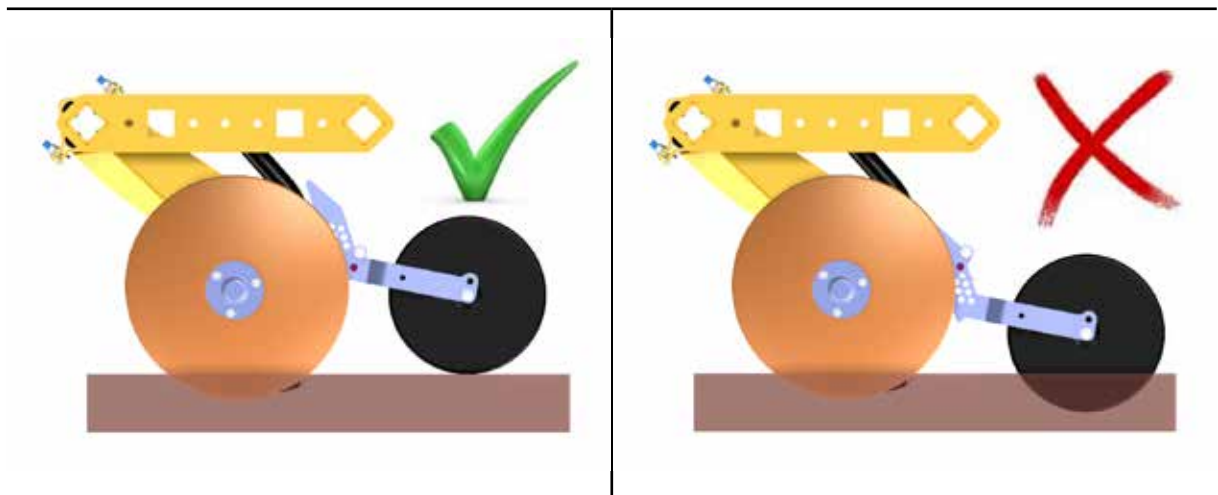

Fig. 42 Press wheel

7.5 Hopper extension

The hopper extension increases the hopper capacity from a basic 1500 litres to 2000 litres (250 + 250 lit).



Fig. 43 Hopper extension



Alpego S.p.a con Socio Unico
Via Giovanni e Giuseppe Cenzato, 9
36045 - Lonigo (VI) Italy
Tel: 0444 646100
Mail: info@alpego.com
www.alpego.com

Choose only
ALPEGO original
SPARE PARTS

